

Reference Guide

Agilent Technologies Electronic Calibration Modules

RF Two-Port

85091C 85092C 85093C
85096C 85098C 85099C

RF Four-Port

N4431B

Microwave Two-Port

N4690B N4691B N4692A
N4693A N4694A N4696B

Microwave Four-Port

N4432A N4433A



Agilent Technologies

Agilent Part Number: N4693-90001

Printed in USA

Print Date: December 2006

Supersedes: February 2006

© Copyright Agilent Technologies, Inc. 2000–2006

WARRANTY STATEMENT

THE MATERIAL CONTAINED IN THIS DOCUMENT IS PROVIDED “AS IS,” AND IS SUBJECT TO BEING CHANGED, WITHOUT NOTICE, IN FUTURE EDITIONS. FURTHER, TO THE MAXIMUM EXTENT PERMITTED BY APPLICABLE LAW, AGILENT DISCLAIMS ALL WARRANTIES, EITHER EXPRESS OR IMPLIED WITH REGARD TO THIS MANUAL AND ANY INFORMATION CONTAINED HEREIN, INCLUDING BUT NOT LIMITED TO THE IMPLIED WARRANTIES OF MERCHANTABILITY AND FITNESS FOR A PARTICULAR PURPOSE. AGILENT SHALL NOT BE LIABLE FOR ERRORS OR FOR INCIDENTAL OR CONSEQUENTIAL DAMAGES IN CONNECTION WITH THE FURNISHING, USE, OR PERFORMANCE OF THIS DOCUMENT OR ANY INFORMATION CONTAINED HEREIN. SHOULD AGILENT AND THE USER HAVE A SEPARATE WRITTEN AGREEMENT WITH WARRANTY TERMS COVERING THE MATERIAL IN THIS DOCUMENT THAT CONFLICT WITH THESE TERMS, THE WARRANTY TERMS IN THE SEPARATE AGREEMENT WILL CONTROL.

DFARS/Restricted Rights Notice

If software is for use in the performance of a U.S. Government prime contract or subcontract, Software is delivered and licensed as “Commercial computer software” as defined in DFAR 252.227-7014 (June 1995), or as a “commercial item” as defined in FAR 2.101(a) or as “Restricted computer software” as defined in FAR 52.227-19 (June 1987) or any equivalent agency regulation or contract clause. Use, duplication or disclosure of Software is subject to Agilent Technologies’ standard commercial license terms, and non-DOD Departments and Agencies of the U.S. Government will receive no greater than Restricted Rights as defined in FAR 52.227-19(c)(1-2) (June 1987). U.S. Government users will receive no greater than Limited Rights as defined in FAR 52.227-14 (June 1987) or DFAR 252.227-7015 (b)(2) (November 1995), as applicable in any technical data.

Certification

Agilent Technologies, Inc. certifies that this product met its published specifications at the time of shipment from the factory. Agilent Technologies, Inc. further certifies that its calibration measurements are traceable to the United States National Institute of Standards and Technology, to the extent allowed by the Institute's calibration facility, and to the calibration facilities of other International Standards Organization members.

Assistance

Product maintenance agreements and other customer assistance agreements are available for Agilent Technologies, Inc. products. For information about these agreements and for other assistance, contact Agilent. Refer to [“Contacting Agilent” on page 1-15](#).

Safety and Regulatory Information

The safety and regulatory information pertaining to this product is located in the section [“Safety and Regulatory Information” on page 1-18](#).

Safety Notes

The following safety notes are used in this manual. Familiarize yourself with each of the notes and its meaning before operating this instrument. All pertinent safety notes for using this product are located in [“Safety and Regulatory Information” on page 1-18](#)

WARNING **Warning denotes a hazard. It calls attention to a procedure which, if not correctly performed or adhered to, could result in injury or loss of life. Do not proceed beyond a warning note until the indicated conditions are fully understood and met.**

CAUTION Caution denotes a hazard. It calls attention to a procedure that, if not correctly performed or adhered to, could result in damage to or destruction of the instrument. Do not proceed beyond a caution sign until the indicated conditions are fully understood and met.

Technology Licenses

The hardware and / or software described in this document are furnished under a license and may be used or copied only in accordance with the terms of such license.

Printing Copies of Documentation from the Web

To print copies of documentation from the Web, download the PDF file from the Agilent web site:

- Go to www.agilent.com.
- Enter the product model number in the search function.
- Click on the **Manuals** hyperlink.

Contents

1 General Information

Manual Overview	1-2
Prerequisite Knowledge	1-2
Clarifying the Terminology of a Connector Interface	1-2
Accuracy of Electronic Calibration versus Mechanical Calibration	1-2
Models and Options	1-4
8509x Modules (RF Two-Port)	1-4
N4431B Modules (RF Four-Port)	1-6
N469xA/B Modules (Microwave Two-Port)	1-8
8506x Modules	1-10
N4432A and N4433A Modules (Microwave Four-Port)	1-11
Compatible Network Analyzers	1-13
Service and Recertification	1-14
Contacting Agilent	1-15
Returning Devices to Agilent	1-16
Recertification of ECal Modules	1-17
Safety and Regulatory Information	1-18
Safety Notices	1-18
Installation Notices	1-18
Instrument Markings	1-19
Compliance Notices	1-20

2 Preparing to Use the ECal Module

Inspecting ECal Module Kit	2-2
Inspect the Kit Contents	2-2
Record the Serial Number	2-2
Verify Electrical Performance	2-2
Equipment Required but Not Supplied	2-2
8509x Series Kit Contents	2-3
8509x Options	2-3
N4431B Series Kit Contents	2-4
N4431B Options	2-4
N469xA/B Series Kit Contents	2-4
N469xA/B Options	2-6
N4432A and N4433A Series Kit Contents	2-6
N4432A Options	2-7
N4433A Options	2-7
Operating and Safety Precautions	2-8
ESD Damage	2-8
Connector Care	2-8
Input Power Level	2-9
Operating Temperature	2-9
Connecting and Disconnecting ECal Module	2-10
Connect ECal Module to PNA or ENA Analyzer	2-10
Connect ECal Module to VNA Analyzer	2-12

3 Operating the ECal Module

Setting Up a Calibration	3-2
--------------------------	-----

Contents

Required Procedure for All Calibrations.	3-2
Calibration Types Available.	3-3
When to Correct for Isolation	3-3
Calibration Methods for Non-Insertable Devices.	3-4
Finding More Information on Performing a Calibration.	3-6
Validating a Calibration	3-7
Why Validate a Calibration	3-7
Measure Known Standards	3-7
Perform ECal Confidence Check.	3-7
4 Use, Maintenance, and Care of the Devices	
Electrostatic Discharge	4-2
Visual Inspection	4-3
Look for Obvious Defects and Damage First	4-3
Inspect the Mating Plane Surfaces	4-3
Inspect Female Connectors.	4-4
Cleaning Connectors	4-5
Cleaning Coax Connectors.	4-5
Cleaning Precision 7 mm Connectors	4-7
Gaging Connectors.	4-8
Connector Gage Accuracy	4-8
When to Gage Connectors	4-9
Recognizing Gage Types.	4-9
Reading the Connector Gage	4-9
Gaging Procedures	4-13
Making Connections	4-15
3.5 mm, 2.92 mm, 2.4 mm, 1.85 mm, Type-N, 7-16, and Type-F Devices	4-15
7 mm Devices	4-15
Final Connection Using a Torque Wrench	4-16
Separating Connections.	4-18
Handling and Storage	4-19
5 Specifications and Characteristics	
Specifications: Terminology and Definitions	5-2
Environmental Specifications	5-3
Operating Temperature and Accuracy Enhancement	5-3
Barometric Pressure and Relative Humidity	5-4
Characteristic Performance	5-5
8509x Series	5-5
N4431B (3.5 mm)	5-7
N4431B (Type-N 50 Ω).	5-8
N4432A (Type-N 50 Ω).	5-9
N4433A (3.5 mm)	5-9
N469xA/B Series.	5-10
Mechanical Characteristics.	5-12
Pin Depth	5-12
Type-N Characteristics	5-13
Typical Pin Depth Values	5-15

Contents

Supplemental Mechanical Characteristics	5-18
Mechanical Dimensions of the Modules.	5-20
Measurement Uncertainty Calculator	5-24
Download the Vector Network Analyzer Uncertainty Calculator	5-24
6 Replaceable Parts	
Description of This Chapter.	6-2
7 mm Modules and Accessories	6-2
Type-N (50 ohm) Modules and Accessories	6-3
3.5 mm Modules and Accessories	6-4
7-16 Modules and Accessories	6-5
2.92 mm Modules and Accessories	6-6
2.4 mm Modules and Accessories	6-7
1.85 mm Modules and Accessories	6-8
Type-N (75 ohm) Modules and Accessories.	6-9
Type-F Modules and Accessories.	6-10
Other ECal Accessories	6-11

1 General Information

Manual Overview

The purpose of this manual is to help you use your Electronic Calibration (ECal) module confidently and effectively. ECal is a precision, single-connection calibration technique which uses fully traceable and verifiable electronic standards. Each module has unique S-parameter data that is stored in the module's memory. During calibration, ECal transfers this data to the network analyzer to calculate the error terms for your network analyzer.

This manual provides instructions for operating and maintaining your ECal module. Also included are calibration procedures (for supported analyzers), mechanical specifications, and replaceable parts available for each model.

RF Modules

The 8509x and N4431B series provide two-port and four-port calibration solutions with operating frequencies starting at 300 kHz and ending as high as 13.5 GHz.

Microwave Modules

The N469xA and N469xB series (which replace the 8506x series) and the N4432A and N4433A series provide two-port and four-port calibration solutions with operating frequencies starting as low as 300 kHz and ending as high as 67 GHz.

Prerequisite Knowledge

This manual assumes you are trained in proper connector care. Because an accurate calibration depends on the integrity and cleanliness of the connector interface, a damaged connector will invalidate the calibration achieved with that module. Refer to the “Principles of Microwave Connector Care Quick Reference Card” located at the back of this manual.

Clarifying the Terminology of a Connector Interface

In this manual, adapters, ECal modules, and gage masters are referred to by way of their interface connector. For example:

- A female adapter has a female interface.
- A male adapter has a male interface.

A connector gage is referred to by way of the connector it measures. For example:

- A male connector gage has a female interface so it can measure male devices.
- A female connector gage has a male interface so it can measure female devices.

Accuracy of Electronic Calibration versus Mechanical Calibration

As the number of DUT test ports increases, the required number of calibration measurements also increases. This boosts the probability of bad connections and bad calibrations when mechanical calibration standards are used rather than ECal. Also, test port cable repeatability and stability errors are amplified by the increased number of

connections and disconnections. To perform an SOLT 4-port calibration, a minimum of twelve 1-port standards and three 2-port (thru) standards are measured, requiring a total of eighteen connections. The same calibration using a 4-port ECal module (N4431B, N4432A and N4433A) requires only four connections.

Ignoring connection related errors, the following table compares the accuracy of ECal versus mechanical calibration in various calibration options.

Table 1-1 Accuracy of ECal versus Mechanical Calibration

Mechanical Calibration Type	ECal Thru Type	Measurement	ECal	Mechanical Calibration
1-Port; calibration constant (<i>not</i> data-based) SOL	NA	Reflection	++	
1-Port; short, open, sliding load	NA	Reflection	+	
1-Port; data-based, expanded	NA	Reflection		+
2-Port TRL	All types	Reflection Transmission		++ ++
≥ 2-Port; calibration constant SOL; flush Thru ^a	characterized	Reflection Transmission	++	++
	internal unknown	Reflection Transmission	++	
	external flush ^a	Reflection Transmission	++ +	
≥ 2-Port; calibration constant SOL; unknown Thru	characterized	Reflection Transmission	++	++
	internal unknown	Reflection Transmission	++ =	=
≥ 2-Port; data-based, expanded, flush Thru ^a	characterized	Reflection Transmission		+ ++
	internal unknown	Reflection Transmission		+ +
	external flush ^a	Reflection Transmission		+ +
≥ 2-Port; data-based, expanded, unknown Thru	characterized	Reflection Transmission		+ ++
	internal unknown	Reflection Transmission		+ +
++ better; + slightly better; = same				

a. Flush thru should NOT be used when the test port connectors are not the same type as the calibration standards. SMA and 3.5 mm connectors are mateable but are NOT the same type.

Models and Options

This section provides the model number, operating characteristics and connector options available with Agilent RF and microwave ECal modules. You can order ECal modules by selecting the model number followed by the desired options.

8509x Modules (RF Two-Port)

ECal modules from this series are available with the connector types and frequency ranges shown in [Table 1-2 on page 1-5](#). Mixed connector options allow you to configure the module with a different connector type at each port (as shown in [Figure 1-2](#)).

Figure 1-1 Model 85092C Option M0F

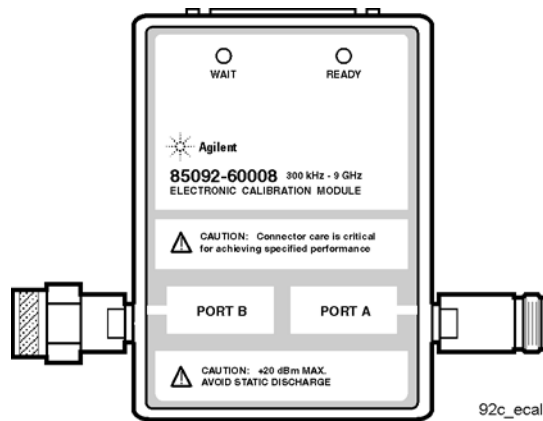

Figure 1-2 Model 85092C Option 104, 201

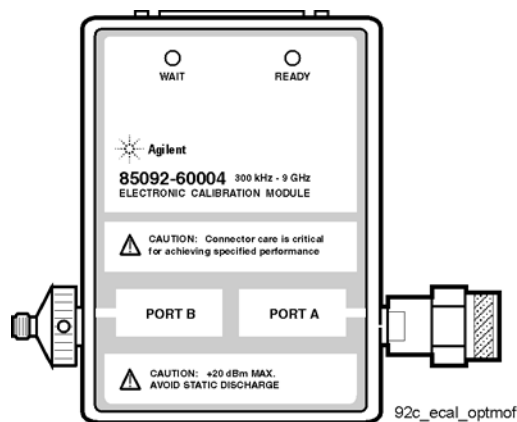

Table 1-2 8509x Modules

Model Number	Connector Type	Operating Frequency	Port A and B Option		
			-m- and -f-	-m- and -m-	-f- and -f-
85091C	7 mm	300 kHz to 9 GHz	No Connector Option 85091-60004		
85092C	Type-N 50 ohm	300 kHz to 9 GHz	M0F 85092-60008	00M 85092-60009	00F 85092-60010
	Mixed connector types – see Table 1-3	300 kHz to 9 GHz	See Table 1-3 85092-60004		
85093C	3.5 mm	300 kHz to 9 GHz	M0F 85093-60008	00M 85093-60009	00F 85093-60010
	Mixed connector types – see Table 1-3	300 kHz to 9 GHz	See Table 1-3 85092-60004		
85096C	Type-N 75 ohm	300 kHz to 3 GHz	M0F 85096-60007	00M 85096-60008	00F 85096-60009
85098C	7-16	300 kHz to 7.5 GHz	M0F 85098-60007	00M 85098-60008	00F 85098-60009
	Mixed connector types – see Table 1-3	300 kHz to 7.5 GHz	See Table 1-3 85092-60004		
85099C	Type-F	300 kHz to 3 GHz	M0F 85099-60009	00M 85099-60010	00F 85099-60011

Table 1-3 8509x Mixed Connector Options

Model Number	Port A Option			Port B Option					
	Type	-f-	-m-	Type	-f-	-m-	Type	-f-	-m-
85092C	Type-N 50Ω	103	104	3.5 mm	201	202	7-16 ^a	205	206
85093C	3.5 mm	101	102	Type-N 50Ω	203	204	7-16 ^a	205	206
85098C	7-16 ^a	105	106	3.5 mm	201	202	Type-N 50Ω	203	204

a. Limits ECal module high frequency to 7.5 GHz.

Other Options	Description
00A	Adds one -m- to -m- and one -f- to -f- adapter.
UK6	Adds commercial calibration certificate with measured data.

N4431B Modules (RF Four-Port)

NOTE The N4431A is no longer available for purchase, but may be returned to Agilent for service and recertification.

ECal modules from this series are available with the connector types and frequency ranges shown in [Table 1-4](#). Mixed connector options (shown in [Table 1-5](#)) allow you to configure the module with a different connector type at each port.

Figure 1-3 Model N4431B Option 010

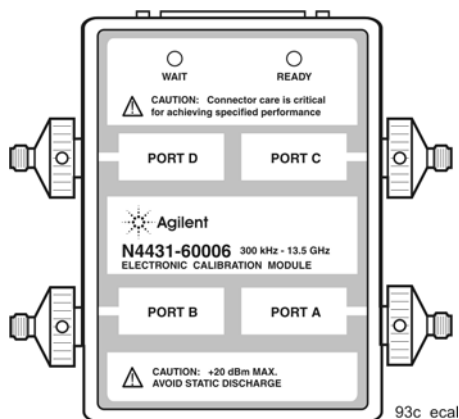

Table 1-4 N4431B Modules

Model Number	Module Number	Connector Type Port A,B,C,D	Operating Frequency	Option
N4431B	N4431-60006	3.5 mm -f-	300 kHz to 13.5 GHz	010
	N4431-60007	Type-N 50Ω -f-	300 kHz to 13.5 GHz	020
	N4431-60008	Mixed connector types – see Table 1-5 on page 1-7	300 kHz to 13.5 GHz	See Table 1-5 on page 1-7

Table 1-5 N4431B Mixed Connector Options

Connector Type	Port A Option	Port B Option	Port C Option	Port D Option
3.5 mm -f-	101	201	301	401
3.5 mm -m-	102	202	302	402
Type-N 50Ω -f-	103	203	303	403
Type-N 50Ω -m-	104	204	304	404
7-16 -f ^a	105	205	305	405
7-16 -m ^a	106	206	306	406

a. Limits ECal module high frequency to 7.5 GHz.

Other Options	Description
UK6	Adds commercial calibration certificate with measured data.

N469xA/B Modules (Microwave Two-Port)

NOTE The N4690/1/6A are no longer available for purchase, but may be returned to Agilent for service and recertification.

ECal modules from this series are available with the connector types and frequency ranges shown in [Table 1-6](#). Mixed connector options are not available with this series.

Figure 1-4 Model N4693A Option M0F

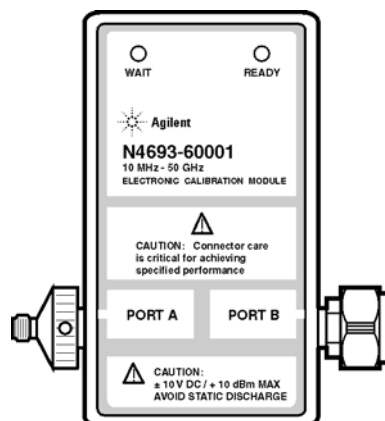

Table 1-6 N469xA/B Modules

Model Number	Connector Type	Operating Frequency	Port A and B Option		
			-m- and -f-	-m- and -m-	-f- and -f-
N4690B	Type-N 50Ω	300 kHz to 18 GHz	M0F	00M	00F
			Module Part Number		
			N4690-60004	N4690-60005	N4690-60006
N4691B	3.5 mm	300 kHz to 26.5 GHz	M0F	00M	00F
			Module Part Number		
			N4691-60004	N4691-60005	N4691-60006
N4692A	2.92 mm	10 MHz to 40 GHz	M0F	00M	00F
			Module Part Number		
			N4692-60001	N4692-60002	N4692-60003
N4693A	2.4 mm	10 MHz to 50 GHz	M0F	00M	00F
			Module Part Number		
			N4693-60001	N4693-60002	N4693-60003
N4694A	1.85 mm	10 MHz to 67 GHz	M0F	00M	00F
			Module Part Number		
			N4694-60001	N4694-60002	N4694-60003
N4696B	7 mm	300 kHz to 18 GHz	No Connector Option		
			Module Part Number		
			N4696-60004		

Other Options	Description
00A	Adds one -m- to -m- and one -f- to -f- adapter (not available with N4696B).
UK6	Adds commercial calibration certificate with measured data.

8506x Modules

ECal modules in this series are no longer available for purchase, but may be returned to Agilent for service and recertification. The 8506x series has been replaced by the N469xA/B series. See [“N469xA/B Modules \(Microwave Two-Port\)”](#) on page 1-8.

Figure 1-5 Model 85062B

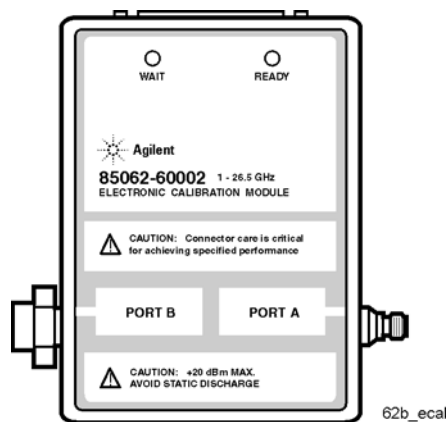

Table 1-7 8506x Modules

Model Number	Connector Type	Operating Frequency
85060B	7 mm	1 to 18 GHz
85062B	3.5 mm	1 to 26.5 GHz
85064B	Type-N 50Ω	1 to 18 GHz

8506xA series modules with serial numbers below 800 need to be retrofitted for operation with the 85097B VNA interface kit. The retrofitting must be done by a qualified Agilent Technologies service office. See [“Contacting Agilent”](#) on page 1-15.

N4432A and N4433A Modules (Microwave Four-Port)

ECal modules from this series are available with the connector types and frequency ranges shown in [Table 1-8](#). Mixed connector options (shown in [Table 1-9](#)) allow you to configure the module with a different connector type at each port.

Figure 1-6 Model N4433A Option 010

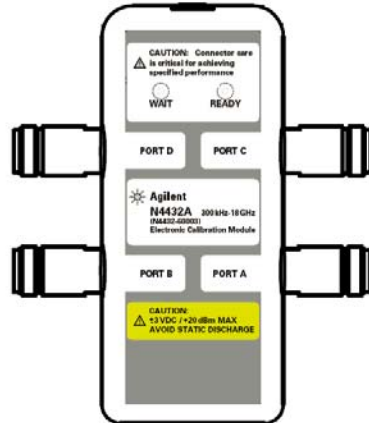

Table 1-8 N4432A and N4433A Modules

Model Number	Module Number	Connector Type Port A,B,C,D	Operating Frequency	Option
N4432A	N4432-60003	Type-N 50Ω -f-	300 kHz to 18 GHz	020
	N4432-60005	Mixed connector types – see Table 1-9 on page 1-12	300 kHz to 18 GHz	See Table 1-9 on page 1-12
N4433A	N4433-60003	3.5 mm -f-	300 kHz to 20 GHz	010
	N4433-60004	Mixed connector types – see Table 1-10 on page 1-12	300 kHz to 20 GHz	See Table 1-10 on page 1-12

Table 1-9 N4432A Mixed Connector Options

Connector Type	Port A Option	Port B Option	Port C Option	Port D Option
3.5 mm -f ^a	101	201	301	401
3.5 mm -m ^a	102	202	302	402
Type-N 50Ω -f-	103	203	303	403
Type-N 50Ω -m-	104	204	304	404

a. Frequency range of ECal module limited by other connectors.

Other Options	Description
UK6	Adds commercial calibration certificate with measured data.
1A7	Adds ISO 17025 compliant calibration.
A6J	Adds ANSI Z540 compliant calibration.

Table 1-10 N4433A Mixed Connector Options

Connector Type	Port A Option	Port B Option	Port C Option	Port D Option
3.5 mm -f-	101	201	301	401
3.5 mm -m-	102	202	302	402

Other Options	Description
UK6	Adds commercial calibration certificate with measured data.
1A7	Adds ISO 17025 compliant calibration.
A6J	Adds ANSI Z540 compliant calibration.

Compatible Network Analyzers

ECal modules operate with the following network analyzer models, as shown in [Table 1-11](#). Not all ECal module and network analyzer combinations have the same features or capabilities. See your network analyzer user guide or online Help.

Table 1-11 Compatible Network Analyzers

Network Analyzers	ECal Module Series					Interface Required
	8509xC	N4431B ^a	N4432/3A	N469xA/B	8506x ^b	
8753/8720-Series Network Analyzers						
8719ES/ET	Yes ^c	Yes ^c	No	Yes ^d	Yes	85097B
8720ES/ET	Yes ^c	Yes ^c	No	Yes ^d	Yes	85097B
8722ES/ET	Yes ^c	Yes ^c	No	Yes ^d	Yes	85097B
8753ES/ET	Yes ^c	Yes ^c	No	Yes ^d	Yes	85097B
PNA Network Analyzers						
E8356/7/8A	Yes	Yes	Yes	Yes ^e	No	USB
E8801/2/3A	Yes	Yes	Yes	Yes ^e	No	USB
N3381/2/3A	Yes	Yes	Yes	Yes ^e	No	USB
E8362/3/4A	Yes	Yes	Yes	Yes ^e	No	USB
E8362/3/4B	Yes	Yes	Yes	Yes ^e	No	USB
E8361A	Yes	Yes	Yes	Yes ^e	No	USB
N5230A	Yes	Yes	Yes	Yes ^e	No	USB
N5242A	Yes	Yes	Yes	Yes ^e	No	USB
ENA Network Analyzers						
E5070/1A/B	Yes	Yes	Yes	Yes	No	USB
E5061/2A	Yes	Yes	Yes	Yes	No	USB

- a. Only ports A and B available when operated with 8753/8720-series analyzers.
- b. 8506x modules are no longer available for purchase.
- c. 8753/8720-series firmware revision 7.68 or higher required.
- d. 8753/8720-series firmware revision 7.74 or higher and adapter cable (part no. 8121-1047) required.
- e. PNA firmware revision 3.0 or higher required with N4692/3A, and N4694A.

NOTE For 8753 network analyzers, RF ECal modules (8509x) may be used below 300 kHz. However, calibration accuracy is *not* specified. The display trace connecting the two points on either side of the 300 kHz boundary may misrepresent actual performance.

Service and Recertification

If your ECal module requires service or recertification, contact the Agilent office nearest you for information about where to send it. The performance of your ECal module can only be verified by specially manufactured equipment and calibration standards from Agilent.

Contacting Agilent

Assistance with test and measurements needs and information on finding a local Agilent office are available on the Web at:

www.agilent.com/find/assist

If you do not have access to the Internet, please contact your Agilent field engineer.

NOTE In any correspondence or telephone conversation, refer to the Agilent product by its model number and full serial number. With this information, the Agilent representative can determine whether your product is still within its warranty period.

Returning Devices to Agilent

If you are returning the product to Agilent, please include a service tag (located near the end of this manual) on which you provide the following information:

- your company name and address
- a technical contact person within your company, and the person's complete telephone number including country code and area code
- the model number and serial number of the ECal module
- type of service required
- a detailed description of the problem and how the device was being used when the problem occurred (such as calibration or measurement)

NOTE When transporting the module, use original or comparable packaging.

Recertification of ECal Modules

The suggested interval for recertification is 12 months. After reviewing the results of the initial recertification, you may establish a shorter interval that reflects greater use and wear of the module.

Where to Send a Module for Recertification

Contact Agilent for information on where to send your kit for recertification. See [“Contacting Agilent” on page 1-15](#). Refer to [“Returning Devices to Agilent” on page 1-16](#) for instructions on the preparation of returning the device.

How Agilent Verifies Your ECal Module

Agilent verifies the specifications of these devices as follows:

1. The residual microwave error terms of the test system are verified with precision airlines and shorts or low frequency resistance that are directly traced to the National Institute of Standards and Technology (NIST). The airline and short characteristics are developed from mechanical measurements. The mechanical measurements and material properties are carefully modeled to give very accurate electrical representation. The mechanical measurements are then traced to NIST through various plug and ring gages and other mechanical measurements.
2. Each module is electrically tested on this system to the specification listed in [Chapter 5, “Specifications and Characteristics.”](#)

These two steps establish a traceable link to NIST for Agilent to the extent allowed by the institute’s calibration facility. The specifications data provided for the module are traceable to NIST through Agilent Technologies.

What Is Provided with a Recertification

- a new calibration sticker affixed to the module
- a certificate of calibration
- a list of United States National Institute of Standards and Technology (NIST) traceable numbers
- a calibration report for each traceable module listing measured values, specifications, and uncertainties
- a new set of S-parameter data (embedded in module memory) if the old set of S-parameters data no longer allows for a calibration that meets all performance specifications

Agilent Technologies offers different types of calibration for the recertification of the module. For more information, contact Agilent. See [“Contacting Agilent” on page 1-15](#).

Safety and Regulatory Information

Review this section to familiarize yourself with safety markings and instructions before you operate the ECal module. This product has been designed and tested in accordance with international standards.

WARNING **The WARNING notice denotes a hazard. It calls attention to a procedure, practice, or the like, that, if not correctly performed or adhered to, could result in personal injury. Do not proceed beyond a WARNING notice until the indicated conditions are fully understood and met.**

CAUTION The CAUTION notice denotes a hazard. It calls attention to an operating procedure, practice, or the like, that, if not correctly performed or adhered to, could result in damage to the product or loss of important data. Do not proceed beyond a CAUTION notice until the indicated conditions are fully understood and met.

Safety Notices

WARNING **To prevent electrical shock, disconnect from instrument before cleaning. Use a dry cloth or one slightly dampened with water to clean the external case parts. Do not attempt to clean internally.**











WARNING **If this product is not used as specified, the protection provided by the equipment could be impaired. This product must be used in a normal condition (in which all means for protection are intact) only.**

Installation Notices

CAUTION This product is designed for use in INSTALLATION CATEGORY II and POLLUTION DEGREE 2, per IEC 61010-1:2001 and 664 respectively.

CAUTION **Ventilation Requirements:** When installing the product in a cabinet, the convection in and out of the product must not be restricted. The ambient temperature (outside the cabinet) must be less than the maximum operating temperature of the system by 4 °C for every 100 watts dissipated in the cabinet. If the total power dissipated in the cabinet is greater than 800 watts, then forced convection must be used.

Instrument Markings

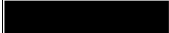
	When you see this symbol on your instrument, you should refer to the instrument's instruction manual for important information.
	This symbol indicates hazardous voltages.
	The laser radiation symbol is marked on products that have a laser output.
	This symbol indicates that the instrument requires alternating current (ac) input.
	The CE mark is a registered trademark of the European Community. If it is accompanied by a year, it indicates the year the design was proven.
	The CSA mark is a registered trademark of the Canadian Standards Association.
1SM1-A	This text indicates that the instrument is an Industrial Scientific and Medical Group 1 Class A product (CISPER 11, Clause 4).
	This symbol indicates that the power line switch is ON.
	This symbol indicates that the power line switch is OFF or in STANDBY position.
 <small>jc84a</small>	The C-Tick mark is a registered trademark of the Australian Spectrum Management Agency.
 	<p>This product complies with the WEEE Directive (2002/96/EC) marking requirements. The affixed label indicates that you must not discard this electrical/ electronic product in domestic household waste.</p> <p>Product Category: With reference to the equipment types in the WEEE Directive Annex I, this product is classed as a "Monitoring and Control instrumentation" product.</p> <p>Do not dispose in domestic household waste.</p> <p>To return unwanted products, contact your local Agilent office, or see http://www.agilent.com/environment/product/ for more information.</p>

Compliance Notices

This product has been designated and tested in accordance with the standards in the Declaration of Conformity (see below), and has been supplied in a safe condition. The documentation contains information and warnings that must be followed by the user to ensure safe operation and to maintain the product in a safe conditions.

Compliance IEC 61000-4-4: 1995 (electrical transients) and IEC 61000-4-2: 1995 (electrostatic discharge): Passes using Criterion C.

Calibration cycle may be interrupted by power line transients applied to external power supply or by electrostatic discharge applied to module. Normal function is restored by power-cycling the module.

Compliance with Canadian EMC Requirements

This ISM device complies with Canadian ICES-001.

Cet appareil ISM est conforme a la norme NMB du Canada.

Declaration of Conformity

A declaration of conformity is on file for the PNA models, and a copy is available upon request.

2 Preparing to Use the ECal Module

Inspecting ECal Module Kit

Inspect the Kit Contents

Verify the case and its contents are not damaged and that all parts are included (see items listed in [Table 2-2](#), [Table 2-3](#), and [Table 2-4](#)). If the case or any device appears damaged, or if the shipment is incomplete, contact Agilent. Agilent will arrange for repair or replacement of incomplete or damaged shipments without waiting for settlement from the transportation company. See [“Contacting Agilent” on page 1-15](#).

Record the Serial Number

ECal modules are individually serialized. Record the serial number and the date of initial use as a reminder for annual recertification. See [“Recertification of ECal Modules” on page 1-17](#).

Table 2-1 Table for Tracking ECal Module Serial Numbers

Module Number	Serial Number	Date

Verify Electrical Performance

To verify electrical performance of the module, see [“Validating a Calibration” on page 3-7](#).

Equipment Required but Not Supplied

VNA Interface Kit (85097B)

The VNA Interface Kit allows you to connect an ECal module to supported vector network analyzers. Microwave ECal modules (N469xA/B series) require an adapter cable (part no. 8121-1047) to operate with the 85097B. The adapter cable is included as an option with the interface kit or can be ordered separately. Refer to [Chapter 6](#), [“Replaceable Parts”](#)

Pin Depth Gages

Gages for measuring recession or protrusion are not provided in the kit. See [Chapter 6](#), [“Replaceable Parts”](#) or contact Agilent to order gages and other test accessories.

8509x Series Kit Contents

The following table lists the items in each 8509x kit. The ECal module listed in the table with each kit describes a unit having a male and female connector (Option M0F). See [Table 1-2 on page 1-5](#) for the part number of other configurations.

Table 2-2 8509x Kit Contents

Qty	Description	Part No.	Qty	Description	Part No.
85091C			85096C		
1	RF Module, 7 mm	85091-60004	1	RF Module, Type-N 75 ohms	85096-60007
1	Torque Wrench 3/4", 1.3 N-m	8710-1766	1	USB A-B Cable, 1.8 m	8121-0506
1	USB A-B Cable, 1.8 m	8121-0506	1	Reference Guide	N4693-90001
1	Extractor, 7 mm Collet	5060-0370	85098C		
1	Reference Guide	N4693-90001	1	RF Module, 7-16	85098-60007
85092C			1	Torque Wrench 1 1/16", 2.2 N-m	8710-2175
1	RF Module, Type-N 50 ohms	85092-60008	1	Open-end Wrench 15/16"	8710-2174
1	Torque Wrench 3/4", 1.3 N-m	8710-1766	1	USB A-B Cable, 1.8 m	8121-0506
1	USB A-B Cable, 1.8 m	8121-0506	1	Reference Guide	N4693-90001
1	Reference Guide	N4693-90001	85099C		
85093C			1	RF Module, Type-F	85099-60009
1	RF Module, 3.5 mm	85093-60008	1	Type F Wrench	8710-1841
1	Torque Wrench 20 mm, 0.9 N-m	8710-1764	1	USB A-B Cable, 1.8 m	8121-0506
1	Torque Wrench 5/16", 0.9 N-m	8710-1765	1	Reference Guide	N4693-90001
1	USB A-B Cable, 1.8 m	8121-0506			
1	Reference Guide	N4693-90001			

8509x Options

- Option 00M configures the module with two male connectors.
- Option 00F configures the module with two female connectors.
- Option M0F configures the module with one male connector and one female connector.
- Option 00A adds one -m- to -m- and one -f- to -f- adapter (not available with 85091C).
- Option UK6 adds a commercial calibration certificate with measured data.
- Option 150 adds a storage box for the ECal module and accessories.

N4431B Series Kit Contents

NOTE The N4431A is no longer available for purchase, but may be returned to Agilent for service and recertification.

The following table lists the items in each N4431B kit. Option 010 is configured with 3.5 mm -f- connectors on all ports and Option 020 is configured with type-N -f- connectors on all ports. See [Table 1-5 on page 1-7](#) for other configurations available.

Table 2-3 N4431B Kit Contents

Qty	Description	Part No.	Qty	Description	Part No.
N4431B Option 010			N4431B Option 020		
1	RF Module, 3.5 mm	N4431-60003 or N4431-60006 ^a	1	RF Module, Type-N 50 ohms	N4431-60004 or N4431-60007 ^a
1	Torque Wrench 20 mm, 0.9 N-m	8710-1764	1	Torque Wrench 3/4", 1.3 N-m	8710-1766
1	Torque Wrench 5/16", 0.9 N-m	8710-1765	1	USB A-B Cable, 1.8 m	8121-0506
1	USB A-B Cable, 1.8 m	8121-0506	1	Reference Guide	N4693-90001
1	Reference Guide	N4693-90001	-	N/A	-

a. Shipped only with N4431B.

N4431B Options

- Option 010 configures the module with 3.5 mm -f- connectors on all ports.
- Option 020 configures the module with Type-N 50 ohm -f- connectors on all ports.
- Option UK6 adds a commercial calibration certificate with measured data.
- Option 150 adds a storage box for the ECal module and accessories.

N469xA/B Series Kit Contents

NOTE The N4690/1/6A are no longer available for purchase, but may be returned to Agilent for service and recertification.

The following table lists the items in each N469xA/B kit. The ECal module listed in the table with each kit describes a unit having a male and female connector (Option M0F). See [Chapter 6 , "Replaceable Parts,"](#) for the part number of other configurations.

Table 2-4 N469xA/B Kit Contents

Qty	Description	Part No.	Qty	Description	Part No.
N4690B			N4693A		
1	Microwave Module, Type-N	N4690-60001 ^a or N4690-60004 ^b	1	Microwave Module, 2.4 mm	N4693-60001
1	Torque Wrench 3/4", 1.3 N-m	8710-1766	1	Torque Wrench 20 mm, 0.9 N-m	8710-1764
1	Open-End Wrench, 1/2 to 9/16"	8710-1770	1	Torque Wrench 5/16", 0.9 N-m	8710-1765
1	USB A-B Cable, 1.8 m	8121-0506	1	Open-End Wrench, 1/2 to 9/16"	8710-1770
1	Reference Guide	N4693-90001	1	Spanner Wrench	08513-20014
N4691B			N4694A		
1	Microwave Module, 3.5 mm	N4691-60001 ^a or N4691-60004 ^b	1	USB A-B Cable, 1.8 m	8121-0506
1	Torque Wrench 20 mm, 0.9 N-m	8710-1764	1	Reference Guide	N4693-90001
1	Torque wrench 5/16", 0.9 N-m	8710-1765	N4694A		
1	Open-End Wrench, 1/2 to 9/16"	8710-1770	1	Microwave Module, 1.85 mm	N4694-60001
1	Spanner Wrench	08513-20014	1	Torque Wrench 20 mm, 0.9 N-m	8710-1764
1	USB A-B Cable, 1.8 m	8121-0506	1	Torque Wrench 5/16", 0.9 N-m	8710-1765
1	Reference Guide	N4693-90001	1	Open-End Wrench, 1/2 to 9/16"	8710-1770
N4692A			1	Spanner Wrench	08513-20014
1	Microwave Module, 2.92 mm	N4692-60001	1	USB A-B Cable, 1.8 m	8121-0506
1	Torque Wrench 20 mm, 0.9 N-m	8710-1764	1	Reference Guide	N4693-90001
1	Torque Wrench 5/16", 0.9 N-m	8710-1765	N4696B		
1	Open-End Wrench, 1/2 to 9/16"	8710-1770	1	Microwave Module, 7 mm	N4696-60001 ^a or N4696-60004 ^b
1	Spanner Wrench	08513-20014	1	Torque Wrench 3/4", 1.3 N-m	8710-1766
1	USB A-B Cable, 1.8 m	8121-0506	1	Open-End Wrench, 1/2 to 9/16"	8710-1770
1	Reference Guide	N4693-90001	1	USB A-B Cable, 1.8 m	8121-0506
			1	Reference Guide	N4693-90001

- a. Shipped only with the "A" model.
b. Shipped only with the "B" model.

N469xA/B Options

- Option 00M configures the microwave module with two male connectors.
- Option 00F configures the microwave module with two female connectors.
- Option M0F configures the module with one male connector and one female connector.
- Option 00A adds one -m- to -m- and one -f- to -f- adapter (not supplied with N4696B).
- Option UK6 adds a commercial calibration certificate with measured data.
- Option 150 adds a storage box for the ECal module and accessories.

N4432A and N4433A Series Kit Contents

The following tables list the items in each N4432A and N4433A kit. For the N4432A kit, Option 020 is configured with type-N 50 Ohm -f- connectors on all ports. For the N4433A kit, Option 010 is configured with 3.5 mm -f- connectors on all ports. See [Table 1-9 on page 1-12](#) and [Table 1-10 on page 1-12](#) for other configurations available.

Table 2-5 N4432A Kit Contents

Qty	Description	Part No.
N4432A Option 020		
1	Microwave Module, Type-N 50 Ohm -f-	N4432-60003
1	Torque Wrench 3/4", 1.3 N-m	8710-1766
1	USB A-B Cable, 1.8 m	8121-0506
1	Reference Guide	N4693-90001

Table 2-6 N4433A Kit Contents

Qty	Description	Part No.
N4433A Option 010		
1	Microwave Module, 3.5 mm -f-	N4433-60003
1	Torque Wrench 20 mm, 0.9 N-m	8710-1764
1	Torque Wrench 5/16", 0.9 N-m	8710-1765
1	USB A-B Cable, 1.8 m	8121-0506
1	Reference Guide	N4693-90001

N4432A Options

- Option 020 configures the module with Type-N 50 ohm -f- connectors on all ports.
- Option UK6 adds a commercial calibration certificate with measured data.
- Option 1A7 adds ISO 17025 compliant calibration.
- Option A6J adds ANSI Z540 compliant calibration.
- Option 150 adds a storage box for the ECal module and accessories.

N4433A Options

- Option 010 configures the module with 3.5 mm -f- connectors on all ports.
- Option UK6 adds a commercial calibration certificate with measured data.
- Option 1A7 adds ISO 17025 compliant calibration.
- Option A6J adds ANSI Z540 compliant calibration.
- Option 150 adds a storage box for the ECal module and accessories.

Operating and Safety Precautions

Observe the following guidelines before connecting or operating your ECal module.

ESD Damage

Protection against electrostatic discharge (ESD) is important while handling and operating your ECal module. Static electricity can build up on your body and can easily damage sensitive components when discharged. Static discharges too small to be felt can cause permanent damage to the unit. To prevent damage from ESD:

- **Use** a grounded antistatic mat in front of your test equipment and wear a grounded wrist strap attached to it when handling or operating the ECal module.
- **Wear** a heel strap when working in an area with a conductive floor.
- **Ground** yourself before you clean, inspect, or make a connection to an ECal module. You can, for example, grasp the grounded outer shell of the analyzer test port or cable connector briefly.
- **Avoid** touching the center conductor of the test ports.

For more information about preventing ESD, see [“Electrostatic Discharge” on page 4-2](#).

Connector Care

Because connectors can become defective due to wear during normal use, all connectors should be inspected and maintained to maximize their service life.

- **Inspect** the mating surface each time a connection is made. Metal particles from connector threads often find their way onto the mating surface when a connection is made or disconnected.
- **Clean** dirt and contamination from the connector mating surface and threads. This simple step can extend the service life of the connector and improve the quality of your calibration and measurements.
- **Gage** connectors periodically. This not only provides assurance of proper mechanical tolerances, and thus connector performance, but can also indicate situations where the potential for damage to another connector may exist.

You should apply connector care to all devices used in the measurement setup. For more detailed information, see [“Visual Inspection” on page 4-3](#).

CAUTION ECal modules can be damaged if you apply excessive torque to the connectors. See [Table 4-1 on page 4-18](#) for required torque settings.

Input Power Level

Before performing a calibration, make sure the input power and DC levels do not exceed the values indicated in [Table 2-7](#).

Table 2-7 Input Power Limits

Parameter	ECal Module Series		
	8509x	N443xA/B	N469xA/B
Maximum Input Power	+20.0 dBm	+20.0 dBm	+10.0 dBm
Maximum DC Level Applied to Test Port	± 20 Volts	± 3 Volts	± 10 Volts

Operating Temperature

The temperature of the ECal module must be within the following temperature range to meet the operating specifications.

- 8509x Series: +20 °C to +30 °C
- N443xA/B Series: +20 °C to +30 °C
- N469xA/B Series: +20 °C to +26 °C

For more details, see [“Environmental Specifications” on page 5-3](#).

Connecting and Disconnecting ECal Module

ECal modules connect to PNA or ENA network analyzers with the USB cable (supplied with the kit). VNA analyzers require the 85097B VNA Interface Kit.

You can connect (or disconnect) ECal modules when the analyzer is on or off, but should avoid doing so while data transfer is in progress.

TIP Modules that have completed a calibration may remain connected to the analyzer (with the USB cable or 85097B Interface Kit).

Connect ECal Module to PNA or ENA Analyzer

ECal modules are controlled and powered by the analyzer through a USB cable. When you connect the module to the analyzer, the analyzer automatically recognizes the type of module, frequency range, and connector type.

CAUTION Exercise the necessary ESD precautions before connecting the ECal module to the analyzer. See “[Electrostatic Discharge](#)” on page 4-2.

To connect ECal module to the PNA or ENA network analyzer:

1. Connect one end of the USB cable to the ECal module as shown in [Figure 2-1 on page 2-11](#).
2. Connect the other end of the cable to the USB port on the front or rear panel of the analyzer (as shown in [Figure 2-2 on page 2-11](#)). Depending on available USB ports, two or more ECal modules may be connected to the analyzer.
3. The red LED (on the module) indicates WAIT until the ECal module reaches operating temperature.
4. When the green LED turns on, the Ecal module is ready for use.

Figure 2-1 USB Connection to Module

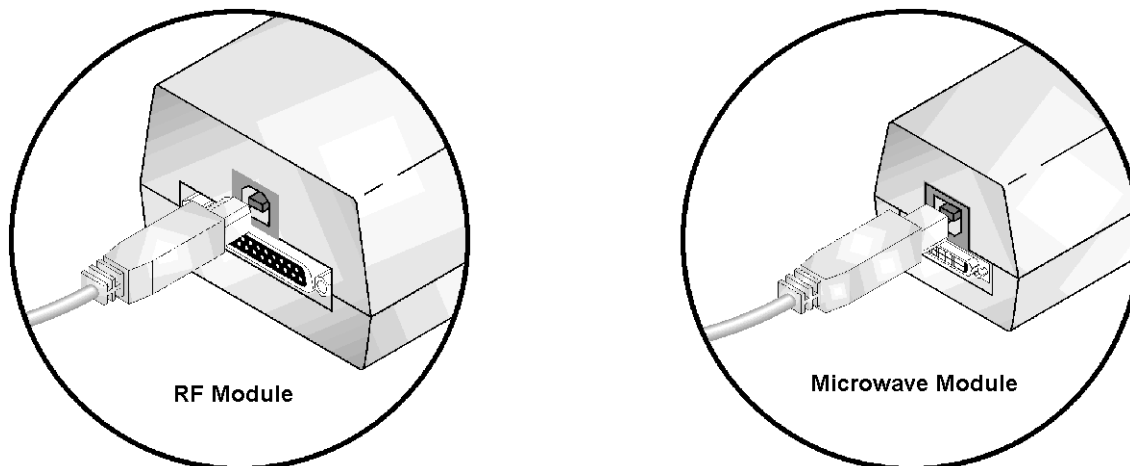
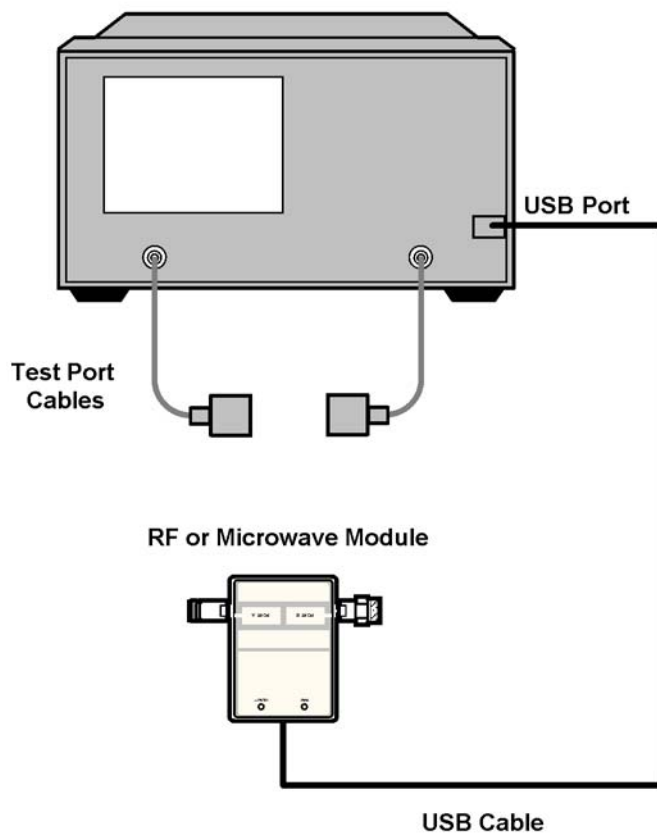

Figure 2-2 USB Connection to PNA or ENA Analyzer



Connect ECal Module to VNA Analyzer

VNA network analyzers require the 85097B Interface Kit, which supplies power and allows data transfer between the analyzer and the ECal module.

The interface kit contains an interface unit, power supply, and cables to connect the interface unit to the analyzer and the ECal module.

An adapter cable, supplied with Option 100, is required to connect microwave ECal modules (N469xA/B series) to the interface unit. This cable may also be ordered separately. For more information about the 85097B, refer to [“Other ECal Accessories” on page 6-11](#).

CAUTION Exercise the necessary ESD precautions before connecting the ECal module to the analyzer. See [“Electrostatic Discharge” on page 4-2](#).

To connect ECal module to the VNA network analyzer:

1. Connect interface unit to VNA:
 - a. Connect one end of the DB25 to DB25 cable to the connector on the interface unit labeled “DB25 Interface to Parallel Interface on Network Analyzer.”
 - b. Connect the other end of the cable to the connector labeled “PARALLEL PORT” on the rear panel of the VNA.

CAUTION Connecting the DB25 cable to any *other* connector on the analyzer **WILL** cause damage.

2. Connect an RF Module:
 - a. Connect one end of the DB25 to DB25 cable to the parallel port connector on the ECal module. See [Figure 2-3 on page 2-13](#).
 - b. Connect the other end of the cable to the connector on the interface unit labeled “DB25 Interface to ECal Module A” or “DB25 Interface to ECal Module B.” See [Figure 2-4 on page 2-13](#). Two ECal modules may be connected at the same time.
3. Connect a Microwave Module (requires adapter cable, part no. 8121-1047):
 - a. Connect the miniature (36-pin) connector on the adapter cable to the parallel port connector on the ECal module. See [Figure 2-3 on page 2-13](#).
 - b. Connect the DB25 connector on the adapter cable to the connector on the interface unit labeled “DB25 Interface to ECal Module A” or “DB25 Interface to ECal Module B.” See [Figure 2-4 on page 2-13](#).
4. Connect the interface power supply to the interface unit and then connect to AC power.

NOTE The LED on the ECal module indicates WAIT until the unit reaches operating temperature.

Figure 2-3 Parallel Port Connection to Module

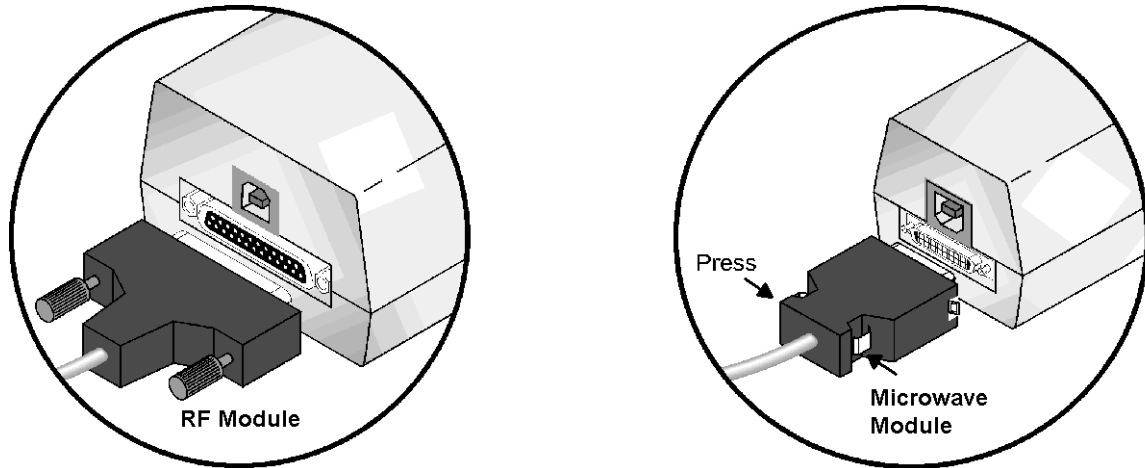
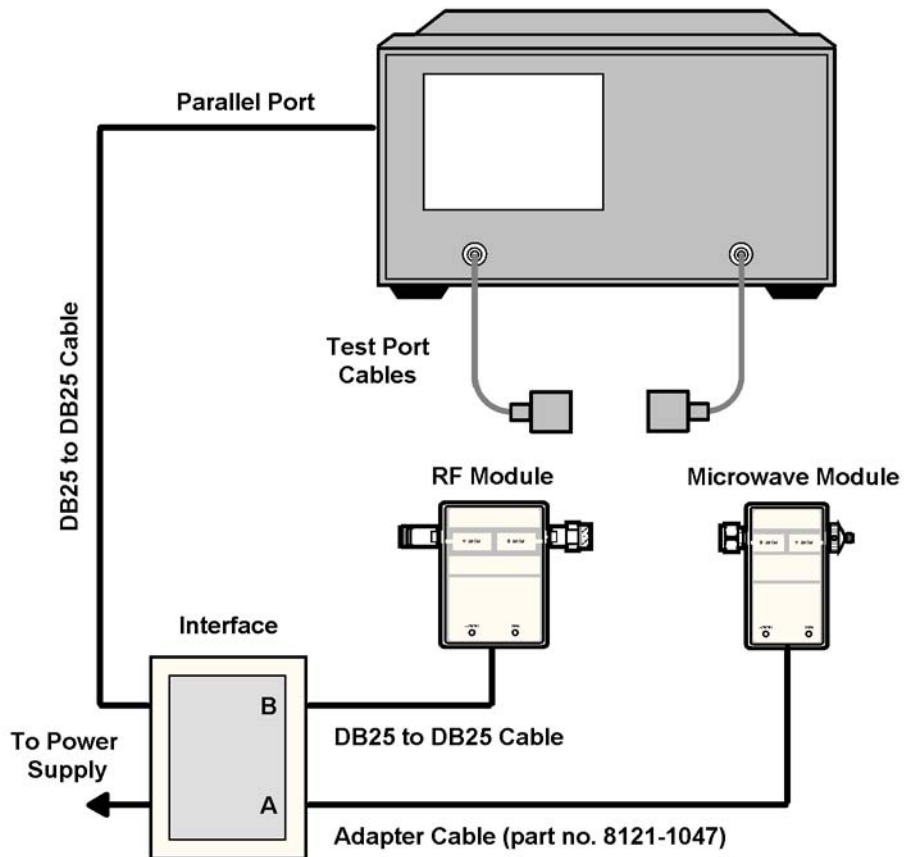

Figure 2-4 Interface Connections to VNA Analyzer



3 Operating the ECal Module

Setting Up a Calibration

Use the following procedure as a starting point for calibrating the network analyzer with an ECal module. For more detailed information about adjusting the settings of your analyzer, refer to the appropriate user guide or online Help.

Required Procedure for All Calibrations

For all calibration types, complete the following steps:

1. Connect an ECal module to the analyzer having the appropriate frequency range and connector type. See [“Connecting and Disconnecting ECal Module” on page 2-10](#).
2. Allow the module to warm up for 15 minutes (20 minutes for a four-port module) or until the module indicates READY.
3. Set up the analyzer and the device under test (DUT) in the measurement configuration. Select the frequency, power, sweep and other stimulus settings.
4. View the response (uncorrected) and optimize the analyzer settings as needed.
5. Remove the DUT from the measurement ports and connect the ECal module.
6. Select the desired calibration type and perform the calibration.
7. Remove the ECal module and re-connect the DUT.

CAUTION Excessive torque can damage ECal module connectors. See [Table 4-1 on page 4-18](#) for the required torque setting for each connector type.

Calibration Types Available

The following table contains the calibration types and advanced settings available for all compatible network analyzers:

Table 3-1 Calibration Types and Advanced Settings Available

Calibration Types	Network Analyzer Series		
	PNA	ENA	8753/8720 Series
1-Port Reflection	Yes	Yes	Yes
Full 2-Port	Yes	Yes	Yes
Full 2-Port (with isolation) ^a	Yes	Yes	Yes
Full 3-Port	Yes	Yes	—
Full 4-Port	Yes	Yes	—
Advanced Settings			
Adapter Removal	Yes	No	No
Flush (zero length) THRU	Yes	No ^b	Yes
Unknown THRU	Yes ^c	No	No
User-Characterization	Yes	Yes ^d	No

a. 8509xC only.

b. Available in mid-2006.

c. Unknown THRU setting is not available with E8801/2/3A analyzers.

d. User-Characterization available with firmware revision A.03.50 (February 2003).

When to Correct for Isolation

Correction for isolation is a consideration when measuring high-loss devices such as saw filters or diplexers. When maximum dynamic range is required, correction for isolation can remove the errors due to crosstalk (between test ports) for transmission measurements.

When you include isolation with a two, three, or four-port calibration, the analyzer automatically applies averaging to reduce noise in the measurement. Without averaging, you will have noise in the measurement of the crosstalk, and could raise the noise floor when the analyzer uses this in its error correction.

The analyzer system isolation is normally sufficient for most measurements, and correction for it is usually unnecessary. As long as crosstalk is below the noise floor, it is best NOT to correct for isolation using ECal. As of PNA firmware release 4.26, measuring isolation as part of the ECal process is no longer supported.

Calibration Methods for Non-Insertable Devices

A "non-insertable" device means that the measurement ports cannot be connected together to establish a THRU connection during calibration for transmission. Because the module typically forms the THRU path, you can use one of the following methods to perform a calibration for non-insertable devices:

Configure ECal Module the Same as Device

The simplest way to calibrate for non-insertable devices is to configure an ECal module with the same connector types as the DUT. RF ECal modules can be configured with mixed connectors to match the connector types on the DUT. Refer to [“Models and Options” on page 1-4](#). You can also configure the module with different connector types by performing a User-Characterization (see below).

Use Adapter Removal Calibration

Adapter removal provides an accurate way to calibrate for non-insertable devices, but requires extra calibration steps to characterize the adapter. The adapter type used for this calibration must be -m- to -m- or -f- to -f- and have the same connector type as the module. In addition, the module must have a male connector on one test port and a female connector on the other test port (of the same connector type).

Use Unknown Thru Calibration

Unknown Thru calibration is currently available with all PNA network analyzers except the E8801/2/3A. It is easy to perform and can be used on any two ports when using a multiport PNA. It causes minimal cable movement if the Thru standard has the same footprint as the DUT. In fact, the DUT can often be the Thru standard. A 1-Port calibration is performed on the both ports. The unknown Thru is connected between the two ports and measured. Next, the user must confirm the Estimated Delay. This requires knowing the phase response to within 1/4 wavelength. If the phase response is unknown, the Delay value can be measured independently and entered in the dialog box.

Perform a User-Characterization

Normally, when you perform a calibration with an ECal module, the error terms for a calibration are computed using the factory characterization (data) stored in the module. User-Characterization allows you change the characterization of the module in two ways:

- *Change the connector configuration:* allows you to add an adapter or fixture to the test port of the module and embed the effects into the characterization of the module. The result of the new characterization extends the reference plane from one or more of the module's test ports to those on the adapter (or fixture).
- *Modify the state settings:* allows you to specify the number of data points (1601 max.) or other stimulus settings the module uses to perform a calibration.

When you perform a User-Characterization, the factory characterization data remains stored in the module's memory. At calibration, you can select the factory characterization or any of the user-defined characterizations stored in the module. The module can store up to five user-defined characterizations (in addition to the factory characterization data).

User-Characterization is currently available with PNA and ENA network analyzers.

To perform a User-Characterization, a calibration kit (having the same connector type as the new reference plane) is required.

For detailed information on calibration methods using a VNA, ENA or PNA series network analyzer, refer to the appropriate user guide or online Help. To use the Internet to view the ENA or PNA online Help or an online VNA user guide, use the steps listed in [“Finding More Information on Performing a Calibration”](#) on page 3-6.

Finding More Information on Performing a Calibration

For detailed information on performing a calibration using a VNA, ENA or PNA series network analyzer, refer to the appropriate user guide or online Help.

- To view the ENA or PNA online Help, press the Help key on the front panel of the network analyzer.
- To view an online VNA user guide, use the following steps:
 1. Go to *http://www.agilent.com*.
 2. Enter your VNA model number (Ex: 8753ES) in the Search box and click **Search**.
 3. Look in the left column for the heading **Refine by Type of Content**, and click on **Manuals & Guides**.
 4. In the left column, click on **User Guide**.
 5. In the right column, click on the title/hyperlink for the User Guide PDF you want to view. If the User Guide you want to view isn't listed on the Web page that is seen initially, click on the **More** hyperlink (if displayed).

CAUTION Do not perform a calibration procedure unless you have cleaned and visually inspected all connectors and have taken the necessary ESD precautions.

Validating a Calibration

Once a calibration has been performed, its performance should be checked before making device measurements.

Why Validate a Calibration

There are several sources of error that can invalidate a calibration:

- bad cables
- dirty or worn connectors
- operator error
- measurement uncertainties from interpolation

Measure Known Standards

Measuring known devices, other than calibration standards, is a way of verifying that the network analyzer system is operating properly. Verification kits use accurately known standards with well-defined magnitude and phase response. These kits include precision airlines, mismatch airlines, and precision fixed attenuators. Traceable measurement data is shipped with each kit on disk and verification kits may be re-certified by Agilent. For information about ordering verification kits, see [“Contacting Agilent” on page 1-15](#).

Perform ECal Confidence Check

ECal Confidence Check is a simple way to check the accuracy of a calibration (performed with mechanical standards or an ECal module). The confidence check allows you to measure an impedance state in the ECal module, called the confidence state, and compare it with factory measured data (of the same confidence state). ECal Confidence Check overlays the two traces so that the differences between the stored state and the measured state can be easily viewed.

Before performing a confidence check, the analyzer must be calibrated and the calibration type should be appropriate for the parameter being checked. For example, you cannot measure the confidence state with S22 if an S11 1-port calibration is active.

NOTE ECal Confidence Check is not available with ENA-L series network analyzers.

For detailed information on performing an ECal Confidence Check using a VNA, ENA or PNA series network analyzer, refer to the appropriate user guide or online Help. To use the Internet to view the ENA or PNA online Help or an online VNA user guide, use the steps listed in [“Finding More Information on Performing a Calibration” on page 3-6](#).

4 Use, Maintenance, and Care of the Devices

Electrostatic Discharge

Protection against electrostatic discharge (ESD) is essential while connecting, inspecting, or cleaning devices attached to static-sensitive circuits (such as those found in network analyzers and ECal modules).

Static electricity can build up on your body and can easily damage sensitive internal circuit elements when discharged. Static discharges too small to be felt can cause permanent damage. Devices such as calibration components and devices under test (DUTs), can also carry an electrostatic charge. To prevent damage to network analyzer components and devices:

- *always* wear a grounded wrist strap having a 1 M Ω resistor in series with it when handling components and devices or when making connections to the test set.
- *always* use a grounded, conductive table mat while making connections.
- *always* wear a heel strap when working in an area with a conductive floor. If you are uncertain about the conductivity of your floor, wear a heel strap.
- *always* ground yourself before you clean, inspect, or make a connection to a static-sensitive device or test port. You can, for example, grasp the grounded outer shell of the test port or cable connector briefly.
- *always* ground the center conductor of a test cable before making a connection to the analyzer test port or other static-sensitive device. This can be done as follows:
 1. Connect a short (from your calibration kit) to one end of the cable to short the center conductor to the outer conductor.
 2. While wearing a grounded wrist strap, grasp the outer shell of the cable connector.
 3. Connect the other end of the cable to the test port.
 4. Remove the short from the cable.

For parts numbers for ESD protection supplies, refer to “[Other ECal Accessories](#)” on [page 6-11](#).

Figure 4-1 ESD Protection Using Mat, Wrist Strap, and Grounded Power Cord

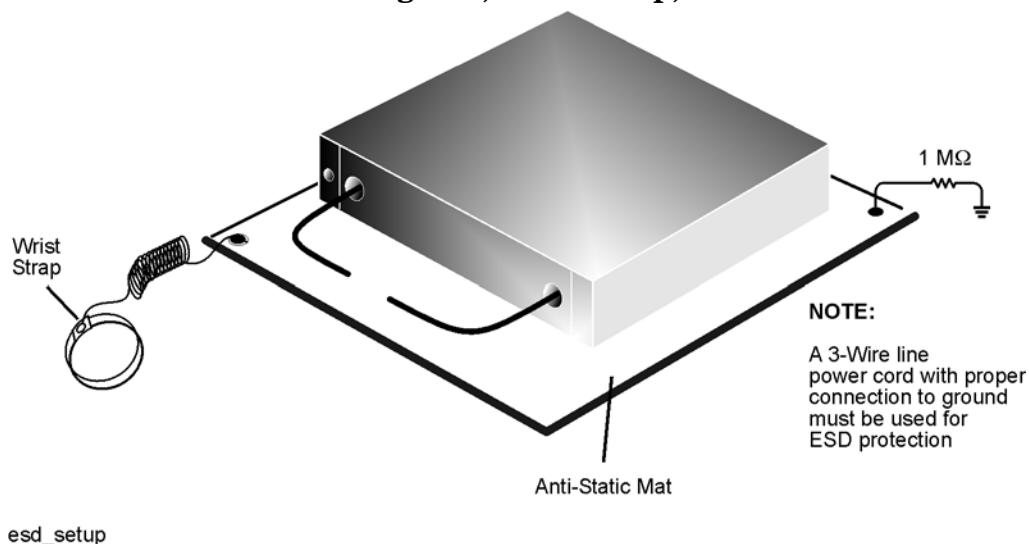

Visual Inspection

Visual inspection and, if necessary, cleaning should be done every time a connection is made. Metal particles from the connector threads may fall into the connector when it is disconnected.

CAUTION Devices with damaged connectors should immediately be discarded or clearly marked and set aside for repair. A damaged device will in turn damage any good connector to which it is attached. Try to determine the cause of the damage before connecting a new, undamaged connector in the same configuration.

In some cases, magnification is necessary to see damage on a connector. Not all defects that are visible only under magnification will affect the electrical performance of the connector. Use the following guidelines when evaluating the integrity of a connector.

Look for Obvious Defects and Damage First

Examine the connectors first for obvious defects and damage: badly worn plating on the connector interface, deformed threads, or bent, broken, or misaligned center conductors.

What Causes Connector Wear?

Connector wear is caused by connecting and disconnecting the devices. The more use the device gets, the faster it wears and degrades. The wear is greatly accelerated when connectors are not kept clean, or are not properly connected. This is especially true with electrically characterized devices such as ECal modules. ECal modules should have a long life if their use is on the order of a few times per week.

The test port connectors on the network analyzer may have many connections each day, and are therefore more subject to wear. It is recommended that an adapter be used as a test port saver to minimize the wear on the connectors. Replace devices with worn connectors.

Inspect the Mating Plane Surfaces

Uniform contact between the connectors at all points on their mating plane surfaces is required for a good connection. See [Figure 4-2](#) for an example of locations of mating plane surfaces. Look especially for deep scratches or dents, and for dirt and metal particles on the connector mating plane surfaces. Also look for signs of damage due to excessive or uneven wear or misalignment.

Figure 4-2 Type-N Connector Pin Depth and Mating Surfaces

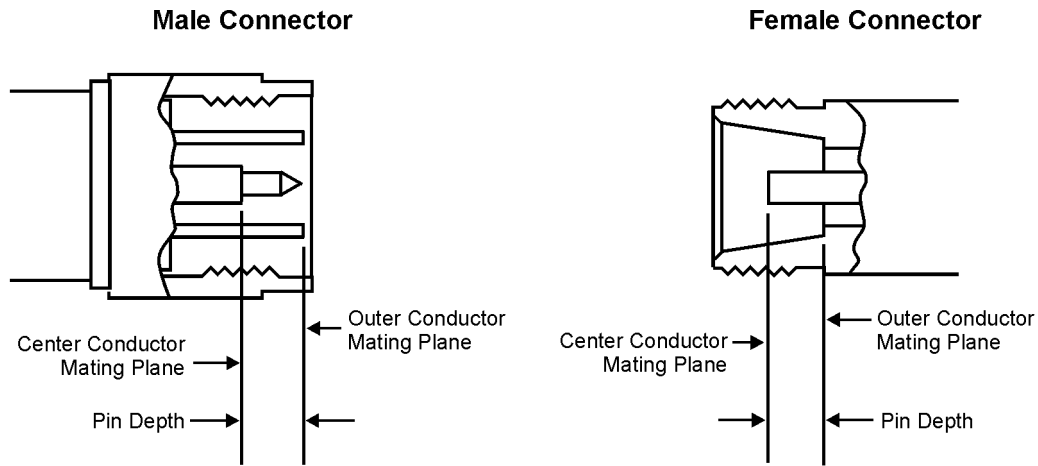

KI31a

Light burnishing of the mating plane surfaces is normal, and is evident as light scratches or shallow circular marks distributed more or less uniformly over the mating plane surface. Other small defects and cosmetic imperfections are also normal. None of these affect electrical or mechanical performance. If a connector shows deep scratches or dents, particles clinging to the mating plane surfaces, or uneven wear, clean and inspect it again.

Inspect Female Connectors

When using slotless connectors like the 3.5 mm or type-N 50 Ω female connectors, pay special attention to the contact fingers on the female center conductor. These can be bent or broken, and damage to them is not always easy to see. A connector with damaged contact fingers will not make good electrical contact and must be repaired or replaced.

NOTE Due to the tighter mechanical specifications of precision devices, inspection is particularly important when you are mating nonprecision to precision devices.

Cleaning Connectors

Clean connector interfaces prolong connector life and produce more accurate and repeatable measurements.

NOTE The following cleaning procedure can be used for most coaxial connectors. For 7 mm connectors, refer to [“Cleaning Precision 7 mm Connectors”](#) on page 4-7.

WARNING Always use protective eyewear when using compressed air or nitrogen.

Cleaning Coax Connectors

1. Use compressed Air or Nitrogen

Use compressed air (or nitrogen) to loosen particles on the connector mating plane surfaces.

You can use any source of clean, dry, low-pressure compressed air or nitrogen that has an effective oil-vapor filter and liquid condensation trap placed just before the outlet hose.

Ground the hose nozzle to prevent electrostatic discharge, and set the air pressure to less than 414 kPa (60 psi) to control the velocity of the air stream. High-velocity streams of compressed air can cause electrostatic effects when directed into a connector. These electrostatic effects can damage the device. For additional information refer to [“Electrostatic Discharge”](#) on page 4-2 earlier in this chapter.

WARNING **Keep isopropyl alcohol away from heat, sparks, and flame. Store in a tightly closed container. Isopropyl alcohol is extremely flammable. In case of fire, use alcohol foam, dry chemical, or carbon dioxide; water may be ineffective.**
Use isopropyl alcohol with adequate ventilation and avoid contact with eyes, skin, and clothing. It causes skin irritation, may cause eye damage, and is harmful if swallowed or inhaled. It may be harmful if absorbed through the skin.
Wash thoroughly after handling. In case of spill, soak up with sand or earth. Flush spill area with water.
Dispose of isopropyl alcohol in accordance with all applicable federal, state, and local environmental regulation.

2. Clean the Connector Threads

CAUTION Use **ONLY** isopropyl alcohol to clean connector surfaces. Any other solvent may damage the insulators, support beads, and seals in the connector.

Never immerse the connector in solvents of any kind. The solvent can become trapped within the assembly and cause SWR, phase, and insertion loss problems.

Moisten (don't soak) a lint-free swab or cleaning cloth with isopropyl alcohol to remove any dirt or stubborn contaminants that cannot be removed with compressed air or nitrogen. Refer to [“Other ECal Accessories” on page 6-11](#) for cleaning swabs and other connector cleaning supplies.

- a. Apply a small amount of isopropyl alcohol to a lint-free swab.
- b. Clean the connector threads.
- c. Let the alcohol evaporate, then blow the threads dry with a gentle stream of clean, low-pressure compressed air or nitrogen. Always completely dry a connector before you reassemble or use it.

3. Clean the Mating Plane Surfaces

- a. Apply a small amount of isopropyl alcohol to a new lint-free cleaning cloth or swab.
- b. Clean the center and outer conductor mating plane surfaces. Refer to [Figure 4-2 on page 4-4](#). When cleaning a female connector; use short strokes to avoid snagging the swab on the center conductor contact fingers.
- c. Let the alcohol evaporate, then blow the mating plane surface dry with a gentle stream of clean, low-pressure compressed air or nitrogen. Always completely dry a connector before you reassemble or use it.

4. Inspect Each Connector

Inspect the connector to make sure that no particles or residue are present.

Cleaning Precision 7 mm Connectors

You do not have to remove the center conductor collet to clean a precision 7 mm connector.

With the Center Collet in Place

1. Dispense a small amount of isopropyl alcohol on the lint free cloth.
2. Retract the connector sleeve threads to expose the connector interface.
3. Gently press the contact end of the connector into the moistened cloth and rotate the connector. The cloth scrubs away dirt and contaminants on the connector interface without damaging it.
4. Blow the connector dry with a gentle stream of compressed air or nitrogen.

NOTE When not in use, keep the cloth in a plastic bag or box so that it does not collect dust or dirt.

For Fixed Connectors (attached to a device that cannot be freely moved)

1. Fold a lint-free cleaning cloth several times.
2. Moisten the cloth with isopropyl alcohol.
3. Press the moistened cloth against the connector interface and rotate the cloth to clean the connector.
4. Blow the connector dry with a gentle stream of compressed air or nitrogen.

Cleaning a Removed Center Collet

Any time you remove the center conductor collet, clean and inspect the interior surfaces as described in [“Cleaning Connectors” on page 4-5](#).

Gaging Connectors

The gages available from Agilent Technologies are intended for preventive maintenance and troubleshooting purposes only. They are effective in detecting excessive center conductor protrusion or recession, and conductor damage on DUTs, test accessories, and ECal module test ports. Do not use the gages for precise pin depth measurements.

Connector Gage Accuracy

The connector gages are only capable of performing coarse measurements. They do not provide the degree of accuracy necessary to precisely measure the pin depth. This is partially due to the repeatability uncertainties that are associated with pin-depth measurements.

With proper technique, the gages are useful in detecting gross pin depth errors on device connectors. To achieve maximum accuracy, random errors must be reduced by taking the average of at least three measurements having different gage orientations on the connector. Even the resultant average can be in error by ± 0.0003 inch (± 0.0075 mm) or more due to systematic (biasing) errors usually resulting from worn gages and gage masters. The information in “[Typical Pin Depth Values](#)” on page 5-15 assumes new gages and gage masters. Therefore, these systematic errors were not included in the uncertainty analysis. As the gages endure more use, the systematic errors can become more significant in the accuracy of the measurement.

The measurement uncertainties are primarily a function of the assembly materials and design, and the unique interaction each device type has with the gage. Therefore, these uncertainties can vary among the different devices.

The observed pin depth limits add in these uncertainties to the typical factory pin depth values to provide practical limits that can be referenced when using the gages.

When measuring pin depth, the measured value (resultant average of three or more measurements) contains measurement uncertainty and is not necessarily the true value. Always compare the measured value with the *observed* pin depth limits (which account for measurement uncertainties) in “[Typical Pin Depth Values](#)” on page 5-15 to evaluate the condition of device connectors.

When to Gage Connectors

Gage a connector at the following times:

- Prior to using an ECal module for the first time: record the pin depth measurement so that it can be compared with future readings. This serves as a good troubleshooting tool when you suspect damage may have occurred to the device.
- If either visual inspection or electrical performance suggests that the connector interface may be out of typical range (due to wear or damage, for example).
- If a module is used by someone else, or on another system or piece of equipment.
- Initially after every 100 connections, and after that as often as experience suggests.

NOTE When using the 7 mm module, you must remove the 7 mm collet before gaging the pin depth of the connectors. Use the collet extraction tool provided in your 7 mm module to remove the collet.

Recognizing Gage Types

A gage is referred to by the sex of the connector it measures. For example, a male gage measures male connectors and therefore has a corresponding female connector.

- See [Figure 4-3 on page 4-10](#) for an illustration of a typical gage for 3.5 mm, 2.92mm, 2.4 mm, and 1.85 mm connectors.
- See [Figure 4-4 on page 4-11](#) for an illustration of a typical gage for type-N connectors.
- See [Figure 4-5 on page 4-12](#) for an illustration of a typical gage for 7 mm connectors.

NOTE A 3.5 mm gage set can measure 3.5 mm and 2.92 mm connectors.
A 2.4 mm gage set can measure 2.4 mm and 1.85 mm connectors.

Reading the Connector Gage

The gage dial is divided up into increments of 0.0001 inch (0.0025 mm) and major divisions of 0.001 inch (0.0025 mm). For type-N gages, see [Figure 4-4 on page 4-11](#). For each revolution of the large dial, the smaller dial indicates a change of 0.01 inch (0.025 mm). Use the small dial as the indicator of multiples of 0.01 inch (0.0025 mm). In most connector measuring applications, this value will be zero.

When making a measurement, the gage dial indicator will travel in one of two directions. If the center conductor is recessed from the zero reference plane, the indicator will move counterclockwise to determine the amount of recession, which is read as a negative value. If center conductor protrudes, the indicator will move clockwise to measure the amount of protrusion, which is read as a positive value. Refer to [“Typical Pin Depth Values” on page 5-15](#) for definitions of protrusion and recession.

Figure 4-3 Typical Gage: 3.5 mm, 2.92 mm, 2.4 mm and 1.85 mm Connectors

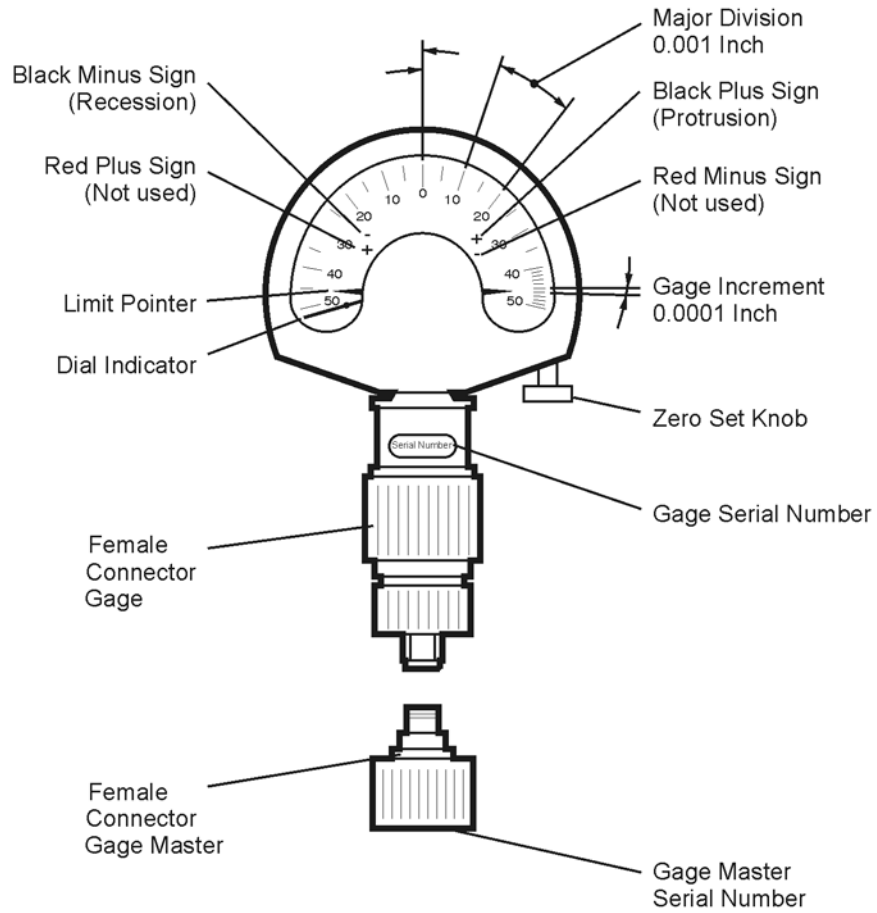

3.5mm

Figure 4-4 Typical Gage: Type-N Connectors

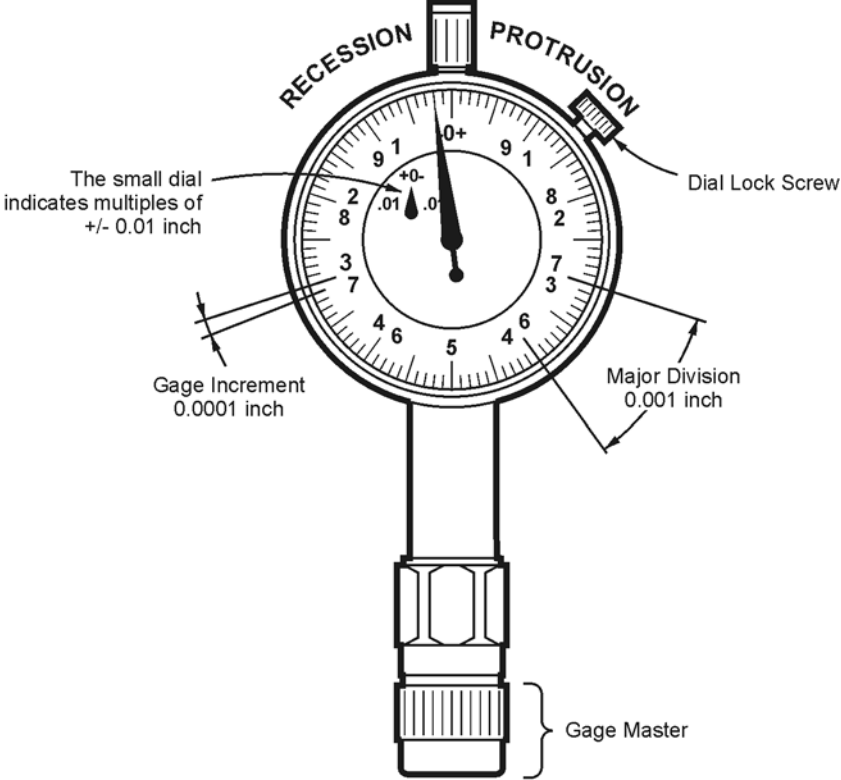

ku311b

Figure 4-5 Typical Gage: 7 mm Connectors

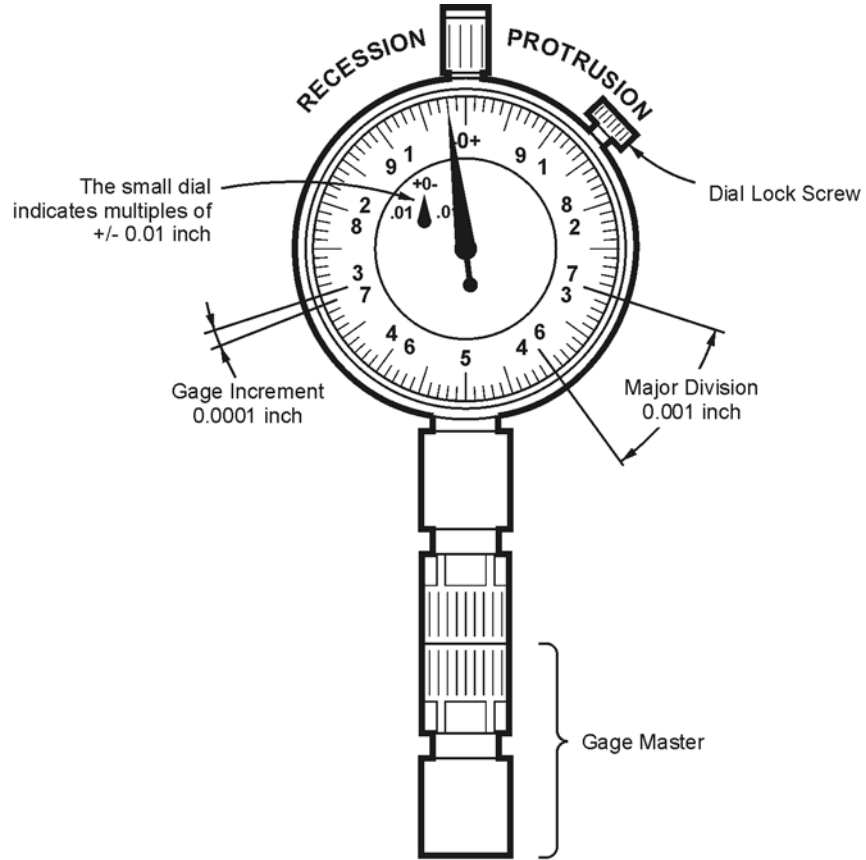

ku312b

Gaging Procedures

Zeroing Connector Gages

For type-N gages, the paired gage master is labeled with an offset value to compensate for its inaccuracy with its gage. This label appears on the bottom of all type-N gage masters that have been paired with gages. When setting a type-N gage with its master, always set the gage to the master offset value shown on the label, not to the zero, unless that is the offset value indicated.

The design of the gages used to measure 3.5 mm, 2.92 mm, 2.4 mm, 1.85 and 7 mm connectors are different than the type-N gage design. The primary difference is that the type-N gages require an offset to compensate for inaccuracies in the gage masters.

1. Select the proper gage for your connector. Always use gages that are intended for pin depth measurements. Refer to [Chapter 6](#) , “[Replaceable Parts](#),” Locate the gage model number listed with the associated connector type.
2. Inspect and clean the gage, gage master, and device to be gaged. Refer to “[Visual Inspection](#)” on [page 4-3](#) and “[Cleaning Connectors](#)” on [page 4-5](#).

CAUTION Before continuing, make sure you are familiar with the proper connection and torque techniques for your connector type. Refer to “[Making Connections](#)” on [page 4-15](#).

3. While holding the gage by the barrel, attach the gage to the gage master. Connect the gage master finger tight. Do not overtighten.
4. Use the torque wrench recommended for use with your connector type to tighten the connecting nut to the gage master. Refer to [Table 4-1](#) on [page 4-18](#).
5. Type-N: Loosen the dial lock screw on the gage and rotate the gage dial so that the pointer corresponds to the correction value noted on the gage master. Do not adjust the gage dial to zero, unless the correction value on the gage master is zero.

3.5mm, 2.4 mm, and 7 mm: The gage pointer should line up exactly with the zero mark on the gage. If not, adjust the zero set knob or rotate the gage dial until the gage pointer lines up exactly with zero.
6. Tighten the dial lock screw and remove the gage master.
7. Attach and torque the gage master once again to verify that the setting is repeatable. Remove the gage master.

Gaging Technique

CAUTION Remove the collet when gaging 7 mm connectors.

1. Connect and torque the device being measured to the gage.
2. Gently tap the barrel of the gage with your finger to settle the gage reading.
3. Type-N and 7mm: Read the gage indicator dial. If the needle has moved clockwise, the center conductor is *protruding* by an amount indicated by the black numbers. If the needle has moved counterclockwise, the center conductor is *recessed* by an amount indicated by the red numbers.

3.5 mm and 2.4 mm: Read the gage indicator dial. Read only the black \pm signs; not the red \pm signs.
4. For maximum accuracy, measure the connector a minimum of three times and take an average of the readings. After each measurement, rotate the gage a quarter-turn to reduce measurement variations that result from the gage or the connector face not being exactly perpendicular to the center axis.
5. Compare the average reading with the observed pin depth limits in the tables located in “[Typical Pin Depth Values](#)” on page 5-15 for each type of connector.

Making Connections

Good connections are essential for accurate calibrations and measurements and require a skilled operator. *The most common cause of measurement error is poor connections.*

3.5 mm, 2.92 mm, 2.4 mm, 1.85 mm, Type-N, 7-16, and Type-F Devices

1. Handle the devices at a static-safe work station, only. See [“Electrostatic Discharge” on page 4-2.](#)
2. Carefully align the connectors. The male connector center pin must slip concentrically into the contact finger of the female connector.

CAUTION Do not turn the device body. Only turn the connector nut. Damage to the center conductor can occur if the device body is twisted.

3. Push the connectors straight together and tighten the connector nut finger tight. Do not twist or screw the connector together. As the center conductors mate, there is usually a slight resistance
4. The preliminary connection is tight enough when the mating plane surfaces make uniform, light contact. Do not overtighten this connection.

A connection in which the outer conductors make gentle contact at all points on both mating surfaces is sufficient. Very light finger pressure is enough to accomplish this.
5. Make sure the connectors are properly supported. Relieve any side pressure on the connection from long or heavy devices or cables.
6. Torque the connection according to the procedures described in [“Final Connection Using a Torque Wrench” on page 4-16.](#)

7 mm Devices

1. Fully extend the connector sleeve on one of the connectors. Spin its knurled connector nut to make sure the threads are fully extended. Fully retract the sleeve on the other connector. The extended sleeve creates a cylinder into which the other connector fits.

If one of the connectors is fixed (such as on a test port), fully extend that connector sleeve and fully retract the sleeve on the moveable connector.
2. Carefully align the connectors. As you make the actual connection, be sure the connectors align perfectly.
3. Push the connectors straight together. Do *not* twist or screw the connectors together.
4. Engage the connector nut (of the connector with the retracted sleeve) over the threads of the other connector (the connector with the extended sleeve). Turn only the connector nut. Let the connector nut pull the two connectors straight together.

5. Do not overtighten this connection. A connection in which the outer conductors make gentle contact at all points on both mating surfaces is sufficient. Very light finger pressure is enough to accomplish this.
6. Make sure the connectors are properly supported. Relieve any side pressure on the connection from long or heavy devices or cables.
7. Torque the connection according to the procedures described in the following section.

Final Connection Using a Torque Wrench

Using a torque wrench guarantees the connection is not too tight, preventing possible connector damage. It also guarantees that all connections are equally tight.

Use the recommended torque wrench to make a final connection. [Table 4-1 on page 4-18](#) provides information on the torque wrench recommended for use with each connector type.

1. Turn the connector nut. This may be possible to do by hand if one of the connectors is fixed (as on a test port). However, it is recommended that you use an open-end wrench to keep the body of the device from turning.
2. Position both wrenches within 90 degrees of each other before applying force. Wrenches opposing each other (greater than 90 degrees apart) will cause a lifting action that can misalign and stress the connections of the device involved. This is especially true when several devices are connected together. Refer to [Figure 4-6](#).

Figure 4-6 Wrench Positions

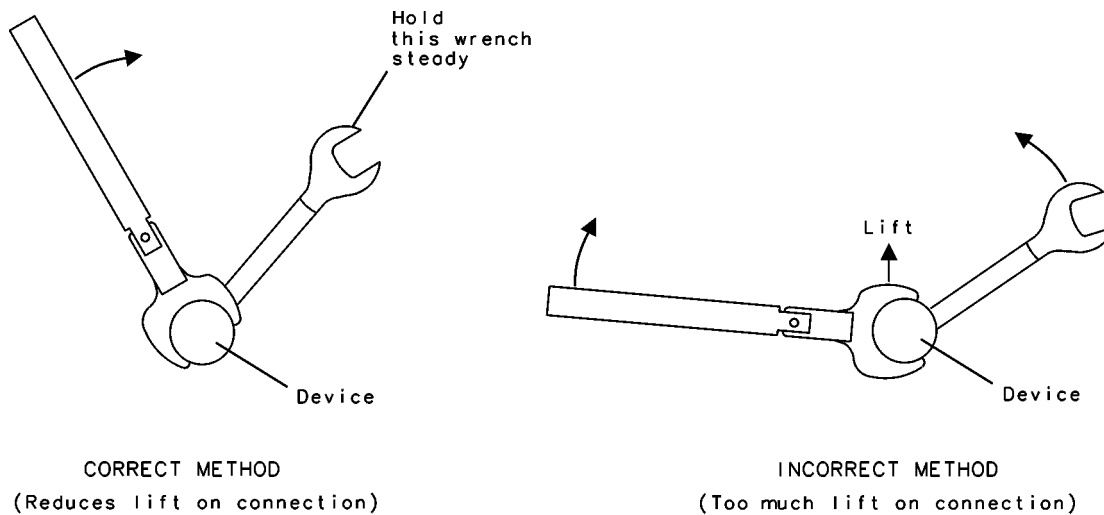

wj56f

3. Hold the torque wrench lightly, at the end of the handle only (beyond the groove). See [Figure 4-7](#).

Figure 4-7 Using the Torque Wrench

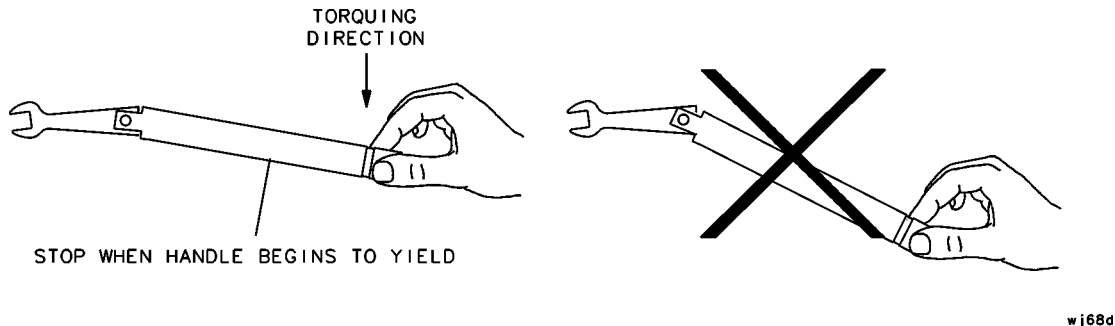

4. Carefully align the connectors. As you make the actual connection, be sure the connectors align perfectly.
5. Push the connectors straight together. Do not twist or screw the connectors together. Engage the connector nut over the threads of the other connector. Turn only the connector nut. Let the connector nut pull the two connectors straight together.

Do not over tighten this connection. A connection in which the outer conductors make gentle contact at all points on both mating surfaces is sufficient. Very light finger pressure is enough to accomplish this.

6. Make sure the connectors are properly supported. Relieve any side pressure on the connection from long or heavy devices or cables.
7. Apply force downward to the wrench handle. This applies torque to the connection through the wrench.

Do not hold the wrench so tightly that you push the handle straight down along its length rather than pivoting it, otherwise you apply an unknown amount of torque.

CAUTION You don't have to fully break the handle of the torque wrench to reach the specified torque; doing so can cause the handle to kick back and loosen the connection. Any give at all in the handle is sufficient torque.

8. Tighten the connection just to the torque wrench break point. The wrench handle gives way at its internal pivot point. Do not tighten the connection further. See [Figure 4-7](#).

Table 4-1 ECal Module Torque Wrench Information

Connector Type	Torque Wrench Part Number	Wrench Opening	Torque Setting	Torque Tolerance ^a
3.5 mm, 2.92 mm, 2.4 mm, 1.85 mm (test port)	8710-1764	20 mm	90 N-cm (8 in-lb)	±9 N-cm (±0.8 in-lb)
3.5 mm, 2.92 mm, 2.4 mm, 1.85 mm (adapters)	8710-1765	5/16 in	90 N-cm (8 in-lb)	±9 N-cm (±0.8 in-lb)
Type-N 50, 75 Ω	8710-1766	3/4 in	135 N-cm (12 in-lb)	±13.5 N-cm (±1.2 in-lb)
7 mm	8710-1766	3/4 in	135 N-cm (12 in-lb)	±13.5 N-cm (±1.2 in-lb)
7-16	8710-2174	1 1/16 in	226 N-cm (20 in-lb)	±22.6 N-cm (±2 in-lb)

a. Many older Agilent calibration module manuals list different torque tolerances for the various torque wrenches. The correct torque tolerance for Agilent torque wrenches is ±10% of the torque setting as listed in this table.

Separating Connections

To avoid lateral (bending) force on the connector mating plane surfaces, always support the devices and connections.

CAUTION Do not turn the device body. Only turn the connector nut. Damage to the center conductor can occur if the device body is twisted.

1. Use an open-end wrench or spanner wrench to prevent the device body from turning.
2. Use another open-end wrench to loosen the connector nut.
3. Complete the separation by hand, turning only the connector nut.
4. Pull the connectors straight apart without twisting, rocking, or bending.

Handling and Storage

- Use the plastic end caps on connectors when not in use.
- Never store modules and adapters loose in a box, in a desk, or in a bench drawer. This is the most common cause of connector damage during storage. Agilent recommends that you purchase the optional ECal Storage Box (not included with an ECal kit). This is a container for securing your ECal module and accessories, such as a USB cable, wrenches, and adaptors. For ordering information, see [“Other ECal Accessories” on page 6-11](#).
- Keep connectors clean.
- Do not touch mating plane surfaces. Natural skin oils and microscopic particles of dirt are easily transferred to a connector interface and are very difficult to remove.
- Do not set connectors contact-end down on a hard surface. The plating and the mating plane surfaces can be damaged if the interface comes in contact with any hard surface.

5 Specifications and Characteristics

Specifications: Terminology and Definitions

The following terms and definitions apply to Agilent’s 8509x, N4431B, and N469xA/B series of ECal modules. The definitions are specific to these modules and are not necessarily valid definitions for other Agilent Technologies products.

Table 5-1 Specifications and Characteristics Terminology

Terms	Definitions
Operating Temperature Range	The temperature range over which the ECal modules maintain conformance to their specifications.
Error-Corrected Temperature Range	The allowable network analyzer ambient temperature drift during measurement calibration and during measurements when network analyzer correction is turned on. It is also the range over which the network analyzer maintains its specified performance while correction is turned on. If this temperature range is exceeded, the error-corrected performance of the network analyzer is degraded.
Measurement Calibration	This calibration determines the corrections necessary for accuracy-enhanced (correction on) measurements.
Connector Pin Depth Values	Pin depth is a relative measurement value between the center conductor and outer conductor mating surfaces. All references to pin depth in this manual treat positive (+) values as protrusions of the center conductor, and negative (–) values as recessions of the center conductor. See “Typical Pin Depth Values” on page 5-15 .
Electrical Specifications	Warranted performance. Specifications include guard bands to account for the expected statistical distribution, measurement uncertainties, and changes in performance due to environmental conditions. Included with Option UK6.
Characteristic Performance	A performance parameter that the product is expected to meet before it leaves the factory, but is not verified in the field and is not covered by the product warranty. A characteristic includes the same guard bands as a specification.
Typical Corrected Performance	Expected performance of an average unit which does not include guard bands. It is not covered by the product warranty.

Environmental Specifications

NOTE Samples of this product have been type-tested in accordance with the Agilent Environmental Test Manual and verified to be robust against the environmental stresses of storage, transportation and end-use; those stresses include but are not limited to temperature, humidity, shock, vibration, altitude and power-line conditions. Test methods are aligned with IEC 60068-2 and levels are similar to MIL-PRF-28800F Class 3.

Table 5-2 Environmental Specifications for all ECal Modules

Specifications	Limits
Temperature	
Operating (8509xC series)	+20 °C to +30 °C
Operating (N443xA/B series)	+20 °C to +30 °C
Operating (N469xA/B series)	+20 °C to +26 °C
Storage	-40 °C to +70 °C
Error-corrected range	±1 °C of measurement calibration temperature
Altitude	
Operation ^a	< 4,500 meters (15,000 feet)
Storage	< 4,500 meters (15,000 feet)
Relative Humidity	Type tested, 0% to 95% at 40 °C, non-condensing
EMI	
Conducted Immunity	IEC 61000-4-6
Radiated Immunity	IEC 61000-4-3
Radiated Emissions	CISPR11

a. The 85097B VNA interface unit is not warranted for use above 3,000 meters (10,000 feet).

Operating Temperature and Accuracy Enhancement

Because the dimensions of critical components may vary over temperature, certain electrical characteristics may change as well. Thus, the operating temperature is a critical factor in its performance, and must be stable before use. In addition, excessive air flow can prevent the ECal module from warming up properly.

Measurement calibration, performance verification, and actual device measurements must be made within ±1 °C of the error-corrected operating temperature range specification of the network analyzer. If the ambient operating temperature drift of the network analyzer exceeds the allowable error-corrected temperature range, a new measurement calibration must be performed to ensure optimum accuracy.

NOTE Avoid prolonged handling of the module, connectors, and cables. Your fingers are a heat source that can increase the temperature of these devices.

Barometric Pressure and Relative Humidity

Barometric pressure and relative humidity also affect module performance. The dielectric constant of the air between the inner and outer conductors of the module changes as the air pressure and humidity change.

Characteristic Performance

Characteristic performance for RF and microwave ECal modules are provided in the following tables, which describe non-warranted performance that most units exhibit.

8509x Series

Characteristic Performance for 85091C (7 mm)

Parameter	Frequency Range			
	300 kHz to 1 GHz	1 to 3 GHz	3 to 6 GHz	6 to 9 GHz
Directivity (dB)	52.0	56.0	55.0	45.0
Source Match (dB)	45.0	44.0	41.0	34.0
Reflection Tracking (\pm dB)	0.04	0.04	0.07	0.1
Transmission Tracking (\pm dB)	0.06	0.06	0.13	0.23
Load Match (dB)	47.0	47.0	46.0	39.0

Characteristic Performance for 85092C (Type-N 50 Ω)

Parameter	Frequency Range			
	300 kHz to 1 GHz	1 to 3 GHz	3 to 6 GHz	6 to 9 GHz
Directivity (dB)	52.0	54.0	52.0	47.0
Source Match (dB)	45.0	44.0	41.0	36.0
Reflection Tracking (\pm dB)	0.04	0.04	0.06	0.07
Transmission Tracking (\pm dB)	0.04	0.04	0.07	0.14
Load Match (dB)	47.0	47.0	44.0	39.0

Characteristic Performance for 85093C (3.5 mm)

Parameter	Frequency Range			
	300 kHz to 1 GHz	1 to 3 GHz	3 to 6 GHz	6 to 9 GHz
Directivity (dB)	52.0	52.0	50.5	47.0
Source Match (dB)	44.0	44.0	39.0	34.0
Reflection Tracking (\pm dB)	0.03	0.03	0.05	0.07
Transmission Tracking (\pm dB)	0.04	0.05	0.07	0.12
Load Match (dB)	47.0	47.0	44.0	40.0

Characteristic Performance for 85096C (Type-N 75Ω)

Parameter	Frequency Range		
	300 kHz to 300 MHz	300 MHz to 1.3 GHz	1.3 to 3 GHz
Directivity (dB)	50.0	48.0	43.0
Source Match (dB)	48.0	45.0	38.0
Reflection Tracking (±dB)	0.03	0.06	0.1
Transmission Tracking (±dB)	0.08	0.09	0.16
Load Match (dB)	43.0	41.0	39.0

Characteristic Performance for 85098C (7-16)

Parameter	Frequency Range			
	300 kHz to 1 GHz	1 to 3 GHz	3 to 6 GHz	6 to 7.5 GHz
Directivity (dB)	47.0	50.0	46.0	45.0
Source Match (dB)	43.0	43.0	38.0	37.0
Reflection Tracking (±dB)	0.03	0.03	0.05	0.06
Transmission Tracking (±dB)	0.05	0.06	0.08	0.10
Load Match (dB)	42.0	43.0	41.0	38.0

Characteristic Performance^a for 85099C (Type-F)

Parameter	Frequency Range		
	300 kHz to 300 MHz	300 MHz to 1.3 GHz	1.3 to 3 GHz
Directivity (dB)	50.0	48.0	43.0
Source Match (dB)	48.0	45.0	38.0
Reflection Tracking (±dB)	0.03	0.07	0.15
Transmission Tracking (±dB)	0.08	0.10	0.17
Load Match (dB)	43.0	41.0	39.0

a. When mated with male connectors with a 0.77 mm (.030 in) to 0.86 (0.34) pin diameter

N4431B (3.5 mm)

The characteristic performance in the following table applies to N4431B Option 010 (3.5 mm female connectors on all ports). The data describes performance when measuring “thru path” A-B, C-D, A-D and B-C.

Characteristic Performance for N4431B Option 010

Parameter	Frequency Range					
	300 kHz to 1 GHz	1 to 3 GHz	3 to 6 GHz	6 to 8 GHz	8 to 9 GHz	9 to 13.5 GHz
Directivity (dB)	57	55	52	50	47	40
Source Match (dB)	50	47	45	44	43	32
Reflection Tracking (\pmdB)	0.03	0.03	0.04	0.04	0.05	0.1
Transmission Tracking (\pmdB)	0.06	0.09	0.12	0.14	0.2	0.33
Load Match (dB)	47	46	45	44	42	28

The characteristic performance in the following table applies to N4431B Option 010 (3.5 mm female connectors on all ports). The data describes performance when measuring “thru path” A-C and B-D.

Characteristic Performance for N4431B Option 010

Parameter	Frequency Range					
	300 kHz to 1 GHz	1 to 3 GHz	3 to 6 GHz	6 to 8 GHz	8 to 9 GHz	9 to 13.5 GHz
Directivity (dB)	57	55	52	50	47	40
Source Match (dB)	50	47	45	44	43	32
Reflection Tracking (\pmdB)	0.03	0.03	0.04	0.04	0.05	0.1
Transmission Tracking (\pmdB)	0.06	0.08	0.1	0.12	0.14	0.3
Load Match (dB)	47	46	45	45	43	29

N4431B (Type-N 50 Ω)

The characteristic performance in the following table applies to N4431B Option 020 (type-N female connectors on all ports). The data describes performance when measuring “thru path” A-B, C-D, A-D and B-C.

Characteristic Performance for N4431B Option 020

Parameter	Frequency Range					
	300 kHz to 1 GHz	1 to 3 GHz	3 to 6 GHz	6 to 8 GHz	8 to 9 GHz	9 to 13.5 GHz
Directivity (dB)	55	52	47	44	42	40
Source Match (dB)	47	43	42	40	39	31
Reflection Tracking (±dB)	0.03	0.04	0.04	0.05	0.06	0.11
Transmission Tracking (±dB)	0.07	0.1	0.14	0.2	0.22	0.35
Load Match (dB)	47	45	40	38	35	26

The characteristic performance in the following table applies to N4431B Option 020 (type-N female connectors on all ports). The data describes performance when measuring “thru path” A-C and B-D.

Characteristic Performance for N4431B Option 020

Parameter	Frequency Range					
	300 kHz to 1 GHz	1 to 3 GHz	3 to 6 GHz	6 to 8 GHz	8 to 9 GHz	9 to 13.5 GHz
Directivity (dB)	55	52	47	44	42	40
Source Match (dB)	47	43	42	40	39	31
Reflection Tracking (±dB)	0.03	0.04	0.04	0.05	0.06	0.11
Transmission Tracking (±dB)	0.07	0.09	0.13	0.15	0.16	0.32
Load Match (dB)	47	45	40	38	36	28

N4432A (Type-N 50 Ω)

The characteristic performance in the following table applies to N4432A Option 020 (type-N female connectors on all ports).

Characteristic Performance for N4432A Option 020

Parameter	Frequency Range				
	300 kHz to 10 MHz	10 MHz to 5 GHz	5 to 9 GHz	9 to 13.5 GHz	13.5 to 18 GHz
Directivity (dB)	45	52	47	41	42
Source Match (dB)	35	41	37	34	34
Reflection Tracking (±dB)	0.1	0.06	0.1	0.15	0.14
Transmission Tracking (±dB) ^a	0.082	0.046	0.062	0.089	0.084
Load Match (dB) ^a	39	45	40	36	37

a. Values based on using the PNA Network Analyzer N5230A Option 240 or 245.

N4433A (3.5 mm)

The characteristic performance in the following table applies to N4433A Option 010 (3.5 mm female connectors on all ports).

Characteristic Performance for N4433A Option 010

Parameter	Frequency Range				
	300 kHz to 10 MHz	10 MHz to 5 GHz	5 to 9 GHz	9 to 13.5 GHz	13.5 to 20 GHz
Directivity (dB)	45	52	47	45	45
Source Match (dB)	36	42	39	37	31
Reflection Tracking (±dB)	0.1	0.06	0.09	0.10	0.18
Transmission Tracking (±dB) ^a	0.078	0.045	0.057	0.069	0.160
Load Match (dB) ^a	39	45	41	39	35

a. Values based on using the PNA Network Analyzer N5230A Option 240 or 245.

N469xA/B Series

Characteristic Performance for N4690B (Type-N 50 Ω)

Parameter	Frequency Range				
	300 kHz to 10 MHz	10 to 500 MHz	500 MHz to 2 GHz	2 to 10 GHz	10 to 18 GHz
Directivity (dB)	40	45	48	46	42
Source Match (dB)	35	40	43	40	35
Reflection Tracking (±dB)	0.07	0.05	0.03	0.03	0.05
Transmission Tracking (±dB)	0.12	0.08	0.07	0.07	0.12
Load Match w/ ECal Thru (dB)	29	35	42	41	38

Characteristic Performance for N4691B (3.5 mm)

Parameter	Frequency Range					
	300 kHz to 10 MHz	10 to 500 MHz	500 MHz to 2 GHz	2 to 10 GHz	10 to 20 GHz	20 to 26.5 GHz
Directivity (dB)	41	46	56	54	48	44
Source Match (dB)	36	41	47	45	44	40
Reflection Tracking (±dB)	0.06	0.05	0.02	0.03	0.04	0.05
Transmission Tracking (±dB)	0.11	0.07	0.05	0.07	0.1	0.12
Load Match w/ ECal Thru (dB)	31	37	45	49	45	40

Characteristic Performance for N4692A (2.92 mm)

Parameter	Frequency Range				
	10 to 200 MHz	200 MHz to 2 GHz	2 to 20 GHz	20 to 30 GHz	30 to 40 GHz
Directivity (dB)	35	45	43	39	38
Source Match (dB)	30	36	35	30	29
Reflection Tracking (±dB)	0.1	0.08	0.08	0.1	0.1
Transmission Tracking (±dB)	0.1	0.14	0.14	0.2	0.25
Load Match (dB)	27	36	37	33	33

Characteristic Performance for N4693A (2.4 mm)

Parameter	Frequency Range					
	10 to 200 MHz	200 MHz to 2 GHz	2 to 10 GHz	10 to 20 GHz	20 to 40 GHz	40 to 50 GHz
Directivity (dB)	32	55	49	45	43	41
Source Match (dB)	25	46	42	37	35	30
Reflection Tracking (\pm dB)	0.05	0.03	0.04	0.05	0.06	0.08
Transmission Tracking (\pm dB)	0.10	0.06	0.08	0.11	0.13	0.17
Load Match (dB)	24	45	42	40	38	36

Characteristic Performance for N4694A (1.85 mm)

Parameter	Frequency Range							
	10 to 200 MHz	200 MHz to 2 GHz	2 to 20 GHz	20 to 30 GHz	30 to 40 GHz	40 to 50 GHz	50 to 60 GHz	60 to 67 GHz
Directivity (dB)	33	50	50	46	44	42	41	38
Source Match (dB)	25	38	39	35	34	33	30	27
Reflection Tracking (\pm dB)	0.05	0.04	0.04	0.05	0.06	0.07	0.08	0.09
Transmission Tracking (\pm dB)	0.15	0.07	0.1	0.11	0.13	0.15	0.19	0.25
Load Match (dB)	25	41	44	42	40	38	36	32

Characteristic Performance for N4696B (7 mm)

Parameter	Frequency Range				
	300 kHz to 10 MHz	10 to 500 MHz	500 MHz to 2 GHz	2 to 10 GHz	10 to 18 GHz
Directivity (dB)	40	46	45	50	42
Source Match (dB)	35	40	40	42	36
Reflection Tracking (\pm dB)	0.07	0.05	0.03	0.03	0.05
Transmission Tracking (\pm dB)	0.11	0.07	0.04	0.07	0.1
Load Match w/ ECal Thru (dB)	30	36	40	45	39

Mechanical Characteristics

Mechanical characteristics, such as center conductor protrusion and pin depth, are *not* warranted performance specifications. They are, however, important supplemental characteristics related to the electrical performance of devices. Agilent Technologies verifies the mechanical characteristics of the devices with special gaging processes and electrical testing. These processes ensure that the device connectors do not exhibit any excess center conductor protrusion or improper pin depth when the module leaves the factory.

“Gaging Connectors” on page 4-8 explains how to use pin-depth gages. Refer to “Typical Pin Depth Values” on page 5-15 for typical and observed pin depth limits.

Pin Depth

Pin depth is the distance the center conductor mating plane differs from being flush with the outer connector mating plane. The pin depth of a connector can be in one of two states: protrusion or recession. The pin depth for a 3.5 mm connector is shown in Figure 5-1, although the description also applies to 2.92 mm, 2.4 mm, or 1.85 mm connectors. Typical pin depths for ECal connectors are listed in “Typical Pin Depth Values” on page 5-15.

Protrusion occurs when the center conductor extends beyond the outer conductor mating plane. It reads as a positive value on the connector gage.

Recession occurs when the center conductor is set back from the outer conductor mating plane. It reads as a negative value on the gage.

Figure 5-1 Pin Depth for a 3.5 mm Connectors

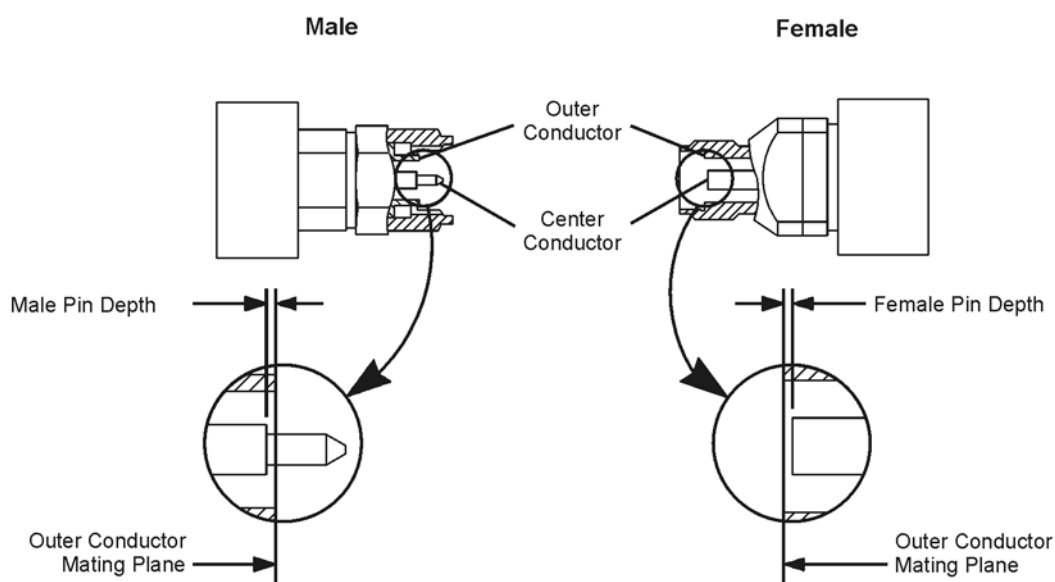

ph51b

Type-N Characteristics

With type-N and 7-16 connectors, the shoulder position of the male contact pin (not the position of the tip) defines the position of the center conductor. The male contact pin slides into the female contact fingers; the inside surfaces of the tip of the female contact fingers on the sides of the male contact pin provide electrical contact.

Type-N connectors differ from most connector types in that the outer conductor mating plane is offset from the mating plane of the center conductor (see Figure 5-2). The outer conductor in the male connector extends in front of the shoulder of the male contact pin. When you make a connection, this outer conductor fits into a recess in the female outer conductor behind the plane defined by the tip of the female contact fingers.

Figure 5-2 Pin Depth for Type-N Connectors

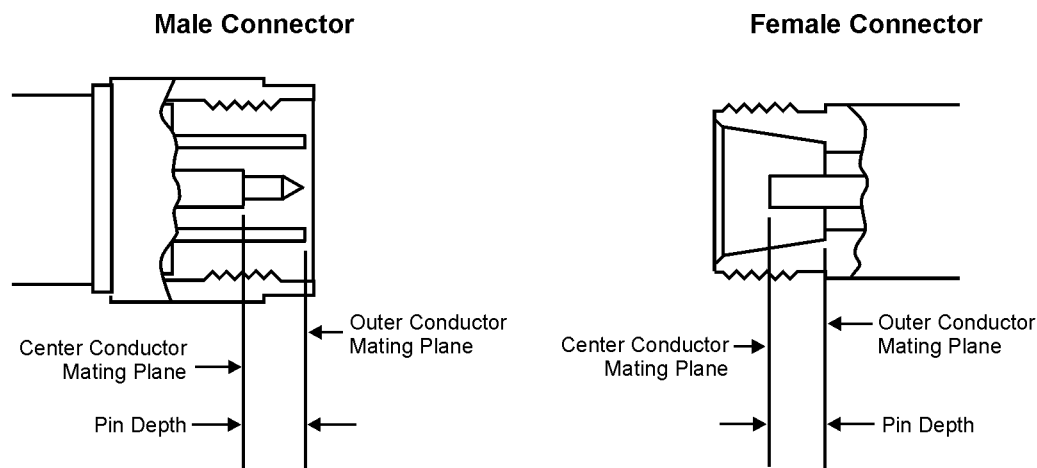

kl31a

Critical Type-N Mechanical Characteristics

CAUTION Never use a type-N connector if the possibility of interference between the shoulder of the male contact pin and the tip of the female contact fingers exists.

Irreparable damage will occur if a male 50 Ω type-N connector is mated to a female 75 Ω type-N connector. If you use both 75 Ω and 50 Ω type-N connectors, mark the 75 Ω connectors so that they are never accidentally mated with 50 Ω connectors. The diameter of the center conductor, male contact pin, and female contact hole are smaller on 75 Ω connectors.

- *Minimum protrusion* of the female center conductor in front of the outer conductor mating plane is 5.182 mm or 0.204 inches.
- *Maximum protrusion* of the female center conductor in front of the outer conductor mating plane is 5.258 mm or 0.207 inches.
- *Minimum recession* of the shoulder of the male contact pin behind the outer conductor mating plane is 5.258 mm or 0.207 inches.

Mechanical Characteristics

- *Maximum recession* of the shoulder of the male contact pin behind the outer conductor mating plane is 5.334 mm or 0.210 inches.

In the Agilent precision specification for type-N connectors, the minimum allowable recession for the male contact pin shoulder is 0.001 inches less than in the MIL-C-39012, Class II specification. Agilent Technologies type-N pin depth gages set “zero” on the gage to be equal to a nominal 5.258 mm (0.207 inches) offset.

As type-N connectors wear, the protrusion of the female contact-fingers generally increases. This is due to the wear of the outer conductor mating plane inside the female connector. It is necessary to check this periodically as it decreases the total center conductor contact separation.

Typical Pin Depth Values

The pin depth value of each device is not specified, but is an important mechanical parameter. The electrical performance of the device depends, to some extent, on its pin depth. The electrical specifications for each module takes into account the effect of pin depth on the device's performance. The following tables list the typical pin depths and measurement uncertainties, and provides observed pin depth limits for the devices. If the pin depth of a device does not measure within the observed pin depth limits, it may be an indication that the device fails to meet electrical specification. Refer to [Figure 5-1](#) and [Figure 5-2](#) for a visual representation of proper pin depth (slightly recessed).

NOTE Agilent Technologies does not supply pin depth gages for 7-16 connectors. The 7-16 module adapter pin depth is set at 0 to -38.1 micrometers recessed from the nominal 1.77 mm offset between inner conductor and outer conductor mating planes.

Table 5-3 Type-N 50 Ω Connector Pin Depth Characteristics

Device	Typical Pin Depth ^a in Micrometers (10 ⁻⁴ inches)	Measurement Uncertainty ^b in Micrometers (10 ⁻⁴ inches)	Observed Pin Depth Limits in Micrometers (10 ⁻⁴ inches)
Type-N 50 Ω ECal Module (85092C, N4432A, N4431B Opt. 020)	-25.4 to -50.8 (-10.0 to -20.0)	+3.8 to -3.8 (+1.5 to -1.5)	-21.6 to -54.6 (-8.5 to -21.5)
Type-N 50 Ω ECal Module (N4690B)	-5.1 to -15.2 (-2.0 to -6.0)	+3.8 to -3.8 (+1.5 to -1.5)	-1.3 to -19.0 (-0.5 to -7.5)
Type-N 50 Ω Adapter	0 to -12.7 (0 to -5.0)	+3.8 to -3.8 (+1.5 to -1.5)	+3.8 to -16.5 (+1.5 to -6.5)

a. Measured from a 5.258 mm (0.207 inches) nominal offset.

b. Approximately +2 sigma to -2 sigma of total measurement uncertainty based on studies performed at the factory using precision digital gages according to recommended procedures.

Table 5-4 3.5 mm Connector Pin Depth Characteristics

Device	Typical Pin Depth in Micrometers (10 ⁻⁴ inches)	Measurement Uncertainty ^a in Micrometers (10 ⁻⁴ inches)	Observed Pin Depth Limits in Micrometers (10 ⁻⁴ inches)
3.5 mm ECal Module (85093C, N4433A, N4431B Opt. 010)	-25.4 to -50.8 (-10.0 to -20.0)	4.1 (1.6)	-29.5 to -54.9 (-8.4 to -21.6)
3.5 mm ECal Module (N4691B)	-2.5 to -15.2 (-1.0 to -6.0)	4.1 (1.6)	1.6 to -19.3 (0.6 to -7.6)
3.5 mm Adapter	0 to 25.4 (0 to 10)	4.1 (1.6)	4.1 to -29.5 (1.6 to -11.6)

a. Approximately +2 sigma to -2 sigma of total measurement uncertainty based on studies performed at the factory using precision digital gages according to recommended procedures.

Table 5-5 7 mm Connector Pin Depth Characteristics

Device	Typical Pin Depth in Micrometers (10 ⁻⁴ inches)	Measurement Uncertainty ^a in Micrometers (10 ⁻⁴ inches)	Observed Pin Depth Limits in Micrometers (10 ⁻⁴ inches)
7 mm ECal Module (85091C, N4432A)	-25.4 to -50.8 (-10.0 to -20.0)	3.8 (1.5)	-21.6 to -54.6 (-8.5 to -21.5)
7 mm ECal Module (N4696B)	-2.5 to -15.2 (-1.0 to -6.0)	3.8 (1.5)	1.3 to -19.0 (0.5 to -7.5)

a. Approximately +2 sigma to -2 sigma of total measurement uncertainty based on studies performed at the factory using precision digital gages according to recommended procedures.

Table 5-6 2.92 mm Connector Pin Depth Characteristics

Device	Typical Pin Depth in Micrometers (10 ⁻⁴ inches)	Measurement Uncertainty ^a in Micrometers (10 ⁻⁴ inches)	Observed Pin Depth Limits in Micrometers (10 ⁻⁴ inches)
2.92 mm ECal Module	-2.5 to -15.2 (-1.0 to -6.0)	3.0 (1.2)	0.5 to -18.2 (0.2 to -7.2)
2.92 mm Adapter	0 to 38.1 (0 to 15.0)	3.0 (1.2)	3.0 to -41.1 (1.2 to -16.2)

a. Approximately +2 sigma to -2 sigma of total measurement uncertainty based on studies performed at the factory using precision digital gages according to recommended procedures.

Table 5-7 2.4 mm Connector Pin Depth Characteristics

Device	Typical Pin Depth in Micrometers (10 ⁻⁴ inches)	Measurement Uncertainty ^a in Micrometers (10 ⁻⁴ inches)	Observed Pin Depth Limits in Micrometers (10 ⁻⁴ inches)
2.4 mm ECal Module	-2.5 to -15.2 (-1.0 to -6.0)	3.0 (1.2)	0.5 to -18.2 (0.2 to -7.2)
2.4 mm Adapter	0 to 38.1 (0 to 15.0)	3.0 (1.2)	3.0 to -41.1 (1.2 to -16.2)

a. Approximately +2 sigma to -2 sigma of total measurement uncertainty based on studies performed at the factory using precision digital gages according to recommended procedures.

Table 5-8 1.85 mm Connector Pin Depth Characteristics

Device	Typical Pin Depth in Micrometers (10 ⁻⁴ inches)	Measurement Uncertainty ^a in Micrometers (10 ⁻⁴ inches)	Observed Pin Depth Limits in Micrometers (10 ⁻⁴ inches)
1.85 mm ECal Module	-2.5 to -15.2 (-1.0 to -6.0)	3.0 (1.2)	0.5 to -18.2 (0.2 to -7.2)
1.85 mm Adapter	0 to 38.1 (0 to 15.0)	3.0 (1.2)	3.0 to -41.1 (1.2 to -16.2)

a. Approximately +2 sigma to -2 sigma of total measurement uncertainty based on studies performed at the factory using precision digital gages according to recommended procedures.

Supplemental Mechanical Characteristics

Table 5-9 8509x Series Mechanical Characteristics

Characteristic	Limits
Net weight with case Standard	2.7 kilograms (5.9 lbs)
Shipping weight Standard	4.3 kilograms (9.5 lbs)
Shipping container dimensions Length Width Height	45.7 cm (17.82 inches) 26.2 cm (10.22 inches) 13.3 cm (5.19 inches)

Table 5-10 N4431B Series Mechanical Characteristics

Characteristic	Limits
Net weight with case Standard	2.9 kilograms (6.3 lbs)
Shipping weight Standard	4.5 kilograms (9.9 lbs)
Shipping container dimensions Length Width Height	45.7 cm (17.82 inches) 26.2 cm (10.22 inches) 13.3 cm (5.19 inches)

Table 5-11 N469xA/B Series and N443xA Series Mechanical Characteristics

Characteristic	Limits
Net weight with case Standard	2.7 kilograms (5.9 lbs)
Shipping weight Standard	4.3 kilograms (9.5 lbs)
Shipping container dimensions Length Width Height	45.7 cm (17.82 inches) 26.2 cm (10.22 inches) 13.3 cm (5.19 inches)

Table 5-12 N443xA Series Mechanical Characteristics

Characteristic	Limits
Net weight with case Standard	2.8 kilograms (6.2 lbs)
Shipping weight Standard	4.4 kilograms (9.7 lbs)
Shipping container dimensions Length Width Height	45.7 cm (17.82 inches) 26.2 cm (10.22 inches) 13.3 cm (5.19 inches)

Mechanical Dimensions of the Modules

Figure 5-3. 8509x Modules (RF Two-Port)

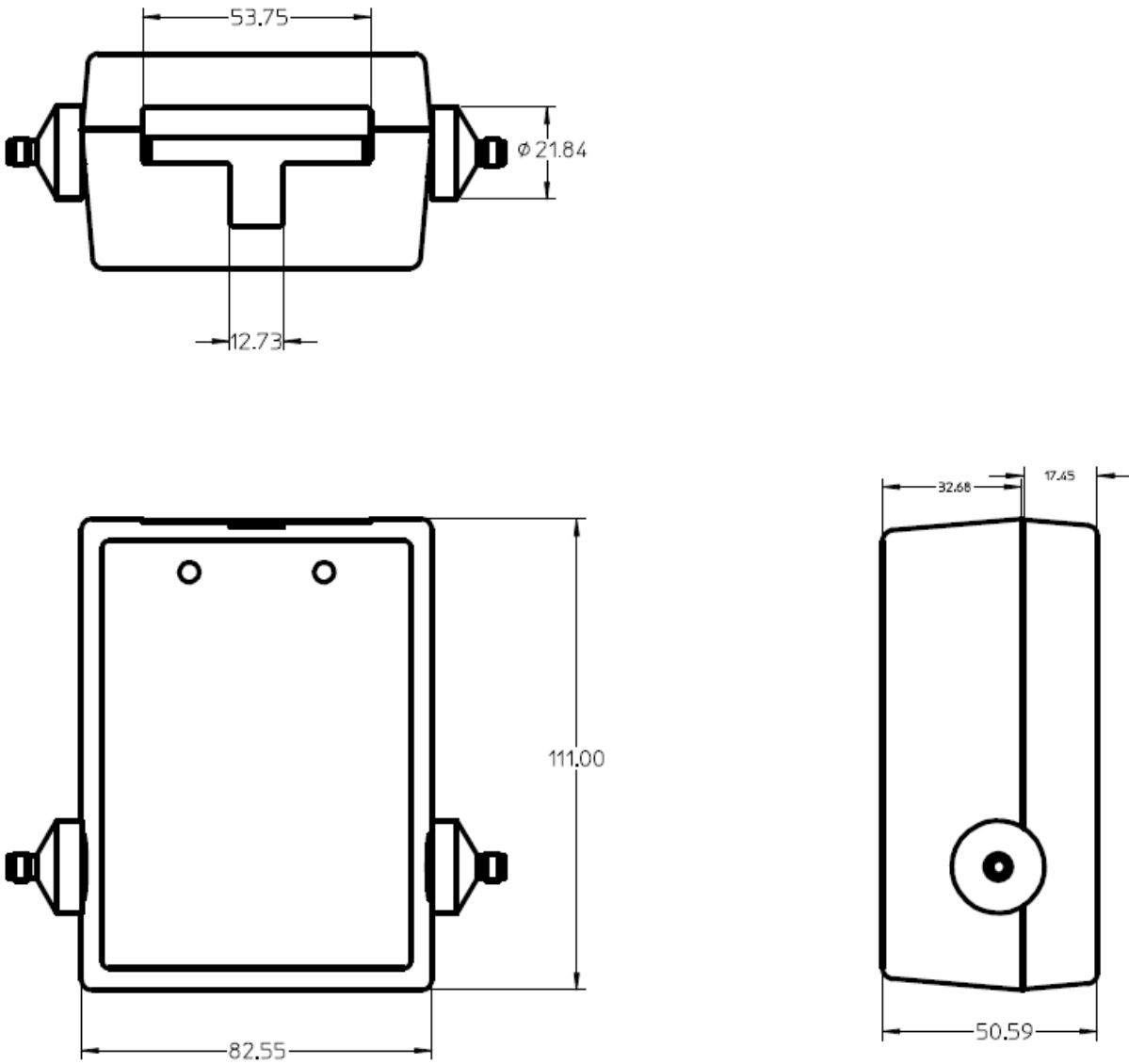

Figure 5-4. N4431B Module (RF Four-Port)

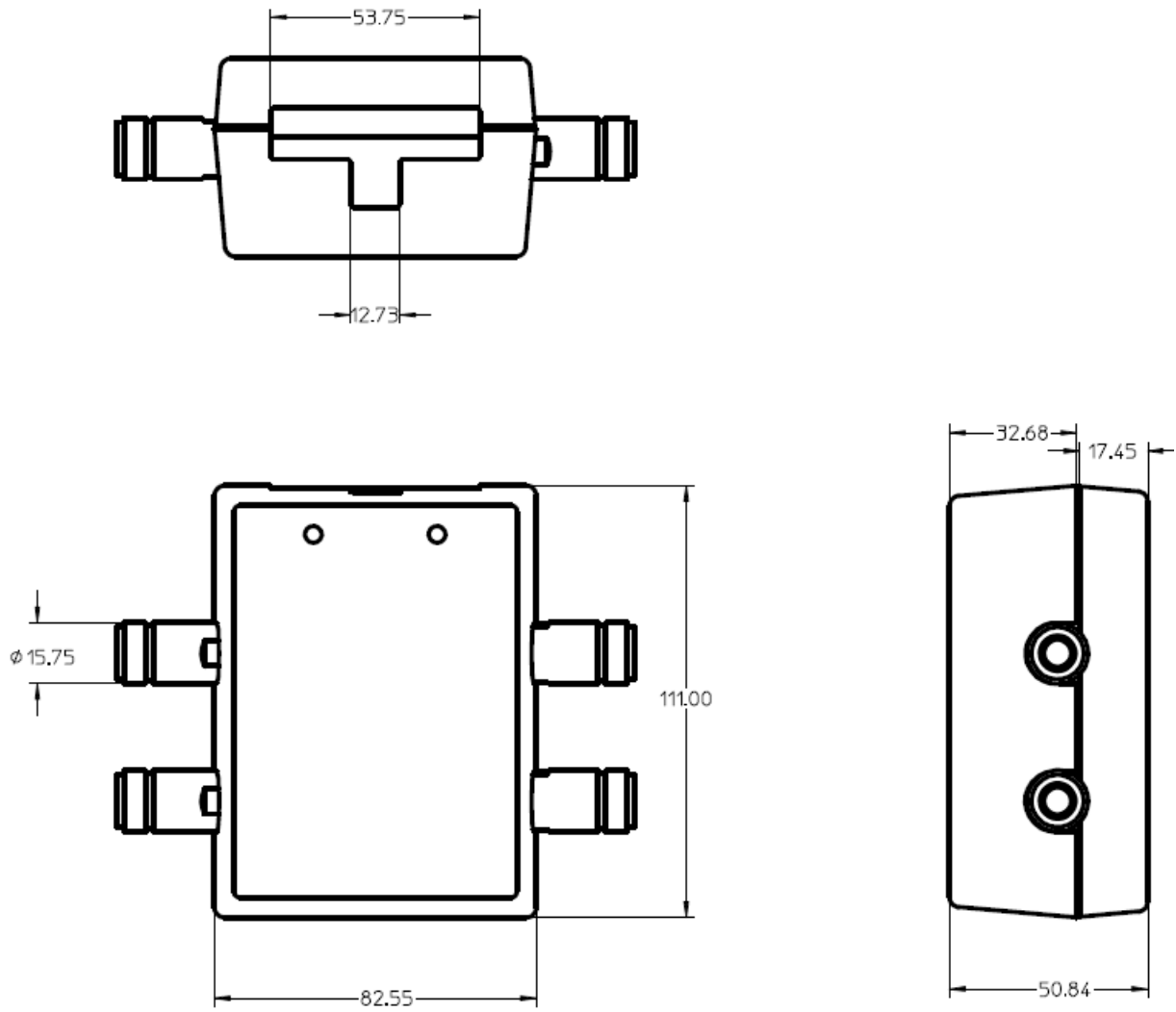

Figure 5-5. N469xA/B Modules (Microwave Two-Port)

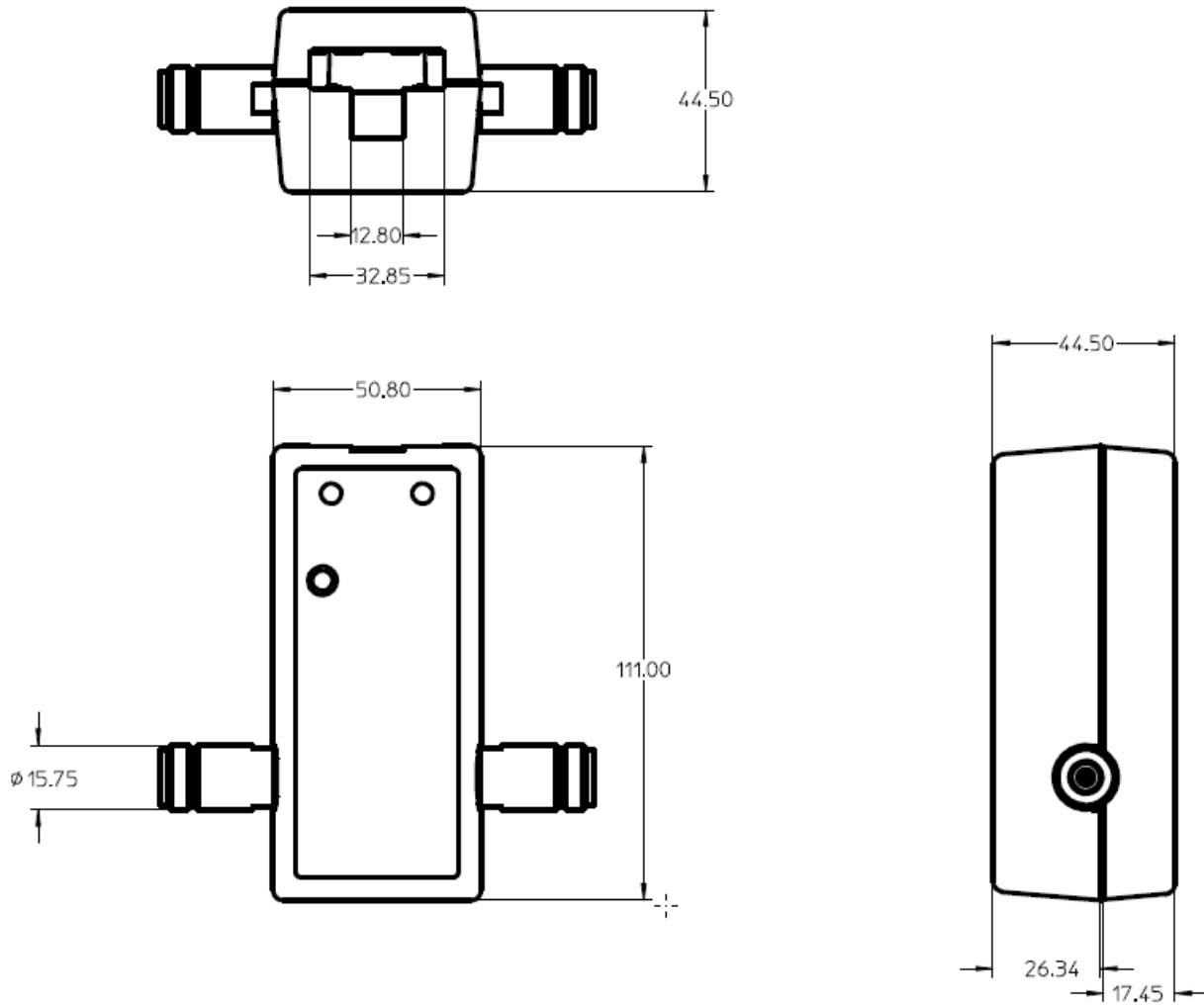
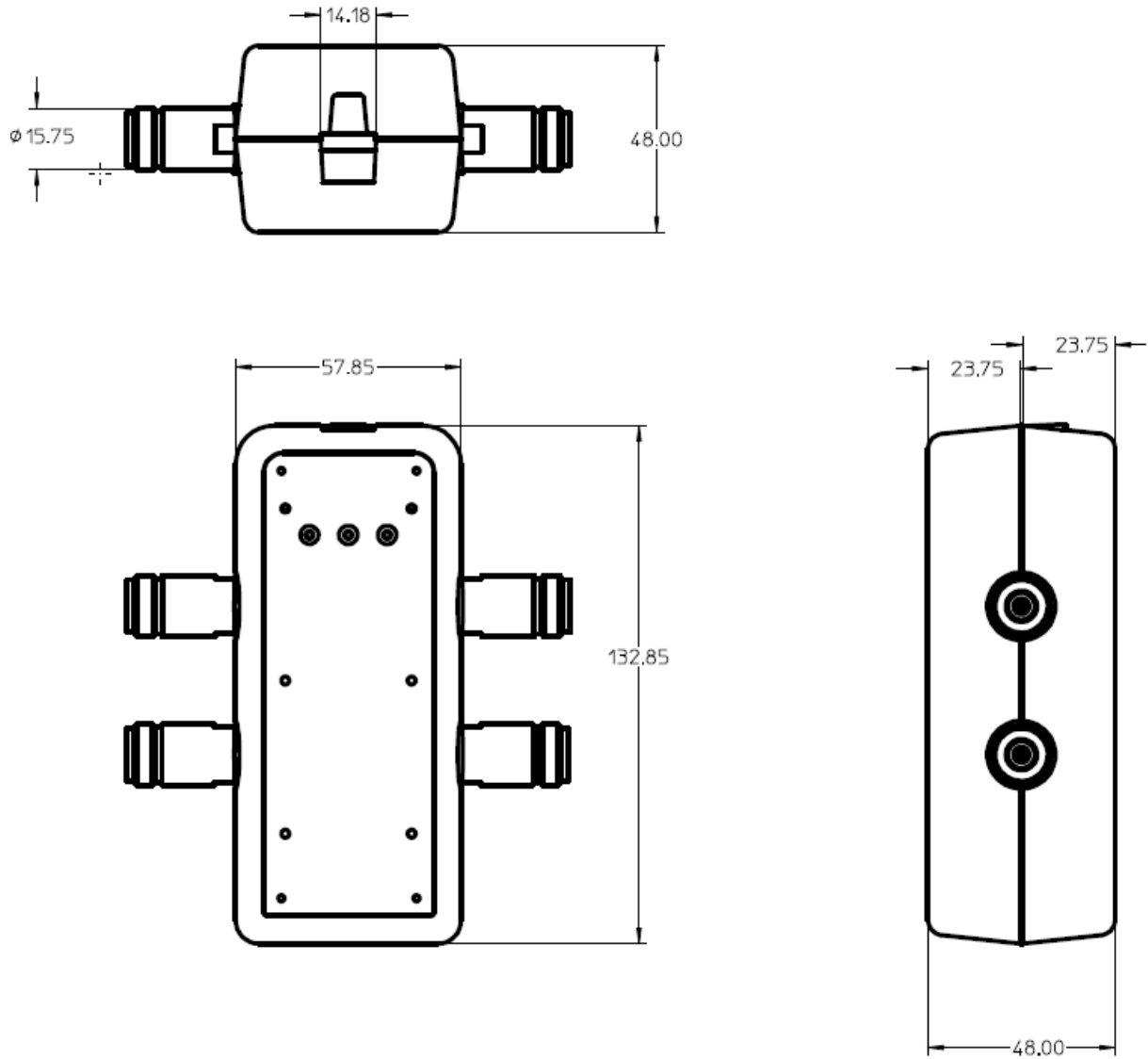

Figure 5-6. N4432A and N4433A Modules (Microwave Four-Port)



Measurement Uncertainty Calculator

This section provides information about determining the uncertainty of the measurements on your network analyzer.

Download the Vector Network Analyzer Uncertainty Calculator

You can download a program from Agilent that provides the measurement uncertainty associated with your vector network analyzer measurement and ECal module. Go to www.agilent.com/find/na_calculator and follow the instructions on the Web site to download the program.

The program uses your Agilent network analyzer model number, your ECal module model number, and electrical limits to calculate specific uncertainty charts for your network analyzer. The program is Microsoft®¹ Windows®² based and uses a Microsoft Excel spreadsheet to calculate, graph, and display uncertainty curves.

-
1. Microsoft® is a U.S. registered trademark of Microsoft Corporation.
 2. Windows® is a U.S. registered trademark of Microsoft Corporation.

6 Replaceable Parts

Description of This Chapter

The following tables contain the replaceable part numbers for ECal options and accessories. Refer to [“Inspecting ECal Module Kit” on page 2-2](#) for the contents of each kit. To order a part, note the description, Agilent part number, and the quantity desired. Telephone or send your order to Agilent Technologies. See [“Contacting Agilent” on page 1-15](#).

7 mm Modules and Accessories

Description ^a	Qty	Part Number
Wrenches		
3/4 in, 135 N-cm (12 in-lb) torque wrench (supplied with 7 mm kits)	1	8710-1766
1/2 in to 9/16 in open-ended wrench (supplied with N4696B)	1	8710-1770
Protective End Caps		
DB25 multi-pin connector cap	as required	1252-4690
7 mm connector cap	as required	1401-0249
36-pin connector cap, ESD protected	as required	N4693-40002
Gages and Accessories		
7 mm pin depth gage and master	1	85050-80012
Other		
7 mm collet extractor tool (supplied with 7 mm kits)	1	5060-0370
Replacement 7 mm collet	1	85050-20001
Electronic calibration module reference manual ^b	1	N4693-90001
USB cable, 1.8 meter	1	8121-0506
Adapter cable, DB25 to AMP Champ (36-pin)	1	8121-1047
Storage box for the ECal module and accessories	1	N4693-60042

a. See [“Clarifying the Terminology of a Connector Interface” on page 1-2](#).

b. See [“Printing Copies of On-Line Documentation” on page iv](#).

Type-N (50 ohm) Modules and Accessories

Description ^a	Qty	Part Number
Adapters (added with Option 00A)		
Type-N (50 Ω) female to female adapter	1	85054-60037
Type-N (50 Ω) male to male adapter	1	85054-60038
Wrenches		
3/4 in, 135 N-cm (12 in-lb) torque wrench (supplied with type-N kits)	1	8710-1766
1/2 in to 9/16 in open-ended wrench (supplied with N4690B)	1	8710-1770
Protective End Caps		
DB-25 multi-pin connector cap	as required	1252-4690
Type-N female connector cap	as required	1401-0225
Type-N male connector cap	as required	1401-0214
36-pin connector cap, ESD protected	as required	N4693-40002
Gages and Accessories		
Type-N pin depth gages (male & female gages & masters)	1	85054-60049
Type-N slotless contact repair kit	1	85054-60056
Type-N slotless contacts (pkg. of 10)	1	85054-60057
Type-N slotless contact (1 only)	1	85054-60058
Other		
Electronic calibration module reference manual ^b	1	N4693-90001
Connector care quick reference card (part of reference manual)	1	08510-90360
USB cable A to B 1.8 meter	1	8121-0506
Adapter cable, DB25 to AMP Champ (36-pin)	1	8121-1047
Storage box for the ECal module and accessories	1	N4693-60042

a. See “Clarifying the Terminology of a Connector Interface” on page 1-2.

b. See “Printing Copies of On-Line Documentation” on page iv.

3.5 mm Modules and Accessories

Description ^a	Qty	Part Number
Adapters (added with Option 00A)		
3.5 mm female to female adapter	1	85052-60012
3.5 mm male to male adapter	1	85052-60014
Wrenches		
20 mm, 90 N-cm (8 in-lb) torque wrench (supplied with all 3.5 mm kits)	1	8710-1764
5/16 in, 90 N-cm (8 in-lb) torque wrench (supplied with N4691B, N4431B, 85093C kits)	1	8710-1765
Spanner wrench (supplied with N4691B)	1	08513-20014
1/2 in to 9/16 in open-ended wrench (supplied with N4691B)	1	8710-1770
Protective End Caps		
DB-25 multi-pin connector cap	as required	1252-4690
3.5 mm connector cap (for module)	as required	1401-0214
3.5 mm female connector cap (for adapter)	as required	1401-0202
3.5 mm male connector cap (for adapter)	as required	1401-0208
36-pin connector cap, ESD protected	as required	N4693-40002

Gages and Accessories		
3.5 mm female pin-depth gage ^b	1	11752-60105
3.5 mm male pin-depth gage ^b	1	11752-60106
3.5 mm repair kit with 10 contacts	1	85052-60049
3.5 mm slotless contacts (pkg. of 10)	1	85052-60050
3.5 mm slotless contact (1 only)	1	85052-60051
Other		
Electronic calibration module reference guide ^c	1	N4693-90001
Connector care quick reference card (part of reference manual)	1	08510-90360
USB cable, 1.8 meter	1	8121-0506
Adapter cable, DB25 to AMP Champ (36-pin)	1	8121-1047
Storage box for the ECal module and accessories	1	N4693-60042

- a. See [“Clarifying the Terminology of a Connector Interface” on page 1-2.](#)
b. A 3.5 mm gage is capable of measuring 3.5 mm and 2.92 mm connectors.
c. See [“Printing Copies of On-Line Documentation” on page iv.](#)

7-16 Modules and Accessories

Description ^a	Qty	Part Number
Adapters (added with Option 00A)		
7-16 female to female adapter	1	11906-80016
7-16 male to male adapter	1	11906-80015
Wrenches		
1-1/16 in, 226 N-cm (20 in-lb) torque wrench (supplied with kit)	1	8710-2175
15/16 in open-ended wrench (supplied with kit)	1	8710-2174
Protective End Caps		
DB-25 multi-pin connector cap	as required	1252-4690
7-16 male connector cap	as required	1401-0417
7-16 female connector cap	as required	1401-0418
Other		
Electronic calibration module reference manual ^b	1	N4693-90001
Connector care quick reference card (part of reference manual)	1	08510-90360
USB Cable, 1.8 meter	1	8121-0506
Storage box for the ECal module and accessories	1	N4693-60042

- a. See [“Clarifying the Terminology of a Connector Interface”](#) on page 1-2.
b. See [“Printing Copies of On-Line Documentation”](#) on page iv.

2.92 mm Modules and Accessories

Description ^a	Qty	Part Number
Adapters (added with Option 00A)		
2.92 mm female to female adapter	1	N4692-60022
2.92 mm male to male adapter	1	N4692-60021
Wrenches		
20 mm, 90 N-cm (8 in-lb) torque wrench (supplied with kit)	1	8710-1764
5/16 in, 90 N-cm (8 in-lb) torque wrench (supplied with kit)	1	8710-1765
Spanner wrench (supplied with kit)	1	08513-20014
1/2 in to 9/16 in open-ended wrench (supplied with kit)	1	8710-1770
Protective End Caps		
2.92 mm connector cap (for module)	as required	1401-0214
2.92 mm female connector cap (for adapter)	as required	1401-0202
2.92 mm male connector cap (for adapter)	as required	1401-0208
36-pin connector cap, ESD protected	as required	N4693-40002
Gages		
3.5 mm female pin-depth gage ^b	1	11752-60105
3.5 mm male pin-depth gage ^b	1	11752-60106
Other		
Electronic calibration module reference manual ^c	1	N4693-90001
Connector care quick reference card (part of reference manual)	1	08510-90360
USB cable, 1.8 meters	1	8121-0506
Adapter cable, DB25 to AMP Champ (36-pin)	1	8121-1047
Storage box for the ECal module and accessories	1	N4693-60042

- a. See [“Clarifying the Terminology of a Connector Interface”](#) on page 1-2.
- b. A 3.5 mm gage is capable of measuring 3.5 mm and 2.92 mm connectors.
- c. See [“Printing Copies of On-Line Documentation”](#) on page iv.

2.4 mm Modules and Accessories

Description ^a	Qty	Part Number
Adapters (added with Option 00A)		
2.4 mm female to female adapter	1	85056-60006
2.4 mm male to male adapter	1	85056-60005
Wrenches		
20 mm, 90 N-cm (8 in-lb) torque wrench (supplied with kit)	1	8710-1764
5/16 in, 90 N-cm (8 in-lb) torque wrench (supplied with kit)	1	8710-1765
1/2 in to 9/16 in open-ended wrench (supplied with kit)	1	8710-1770
Spanner wrench (supplied with kit)	1	08513-20014
Protective End Caps		
2.4 mm connector cap (for module)	as required	1401-0214
2.4 mm female connector cap (for adapter)	as required	1401-0095
2.4 mm male connector cap (for adapter)	as required	1401-0208
36-pin connector cap, ESD protected	as required	N4693-40002
Gages		
2.4 mm female pin-depth gage ^b	1	11752-60107
2.4 mm male pin-depth gage ^b	1	11752-60108
Other		
Electronic calibration module reference manual ^c	1	N4693-90001
Connector care quick reference card (part of reference manual)	1	08510-90360
USB cable, 1.8 meters	1	8121-0506
Adapter cable, DB25 to AMP Champ (36-pin)	1	8121-1047
Storage box for the ECal module and accessories	1	N4693-60042

- a. See [“Clarifying the Terminology of a Connector Interface”](#) on page 1-2.
- b. A 2.4 mm gage is capable of measuring 2.4 mm and 1.85 mm connectors.
- c. See [“Printing Copies of On-Line Documentation”](#) on page iv.

1.85 mm Modules and Accessories

Description ^a	Qty	Part Number
Adapters (added with Option 00A)		
1.85 mm female to female adapter	1	85058-60114
1.85 mm male to male adapter	1	85058-60113
Wrenches		
20 mm, 90 N-cm (8 in-lb) torque wrench (supplied with kit)	1	8710-1764
5/16 in, 90 N-cm (8 in-lb) torque wrench (supplied with kit)	1	8710-1765
Spanner wrench (supplied with kit)	1	08513-20014
1/2 in to 9/16 in open-ended wrench (supplied with kit)	1	8710-1770
Protective End Caps		
1.85 mm connector cap (for module)	as required	1401-0214
1.85 mm female connector cap (for adapter)	as required	1401-0202
1.85 mm male connector cap (for adapter)	as required	1401-0208
36-pin connector cap, ESD protected	as required	N4693-40002
Gages		
2.4 mm female pin-depth gage ^b	1	11752-60107
2.4 mm male pin-depth gage ^b	1	11752-60108
Other		
Electronic calibration module reference manual ^c	1	N4693-90001
Connector care quick reference card (part of reference manual)	1	08510-90360
USB cable, 1.8 meters	1	8121-0506
Adapter cable, DB25 to AMP Champ (36-pin)	1	8121-1047
Storage box for the ECal module and accessories	1	N4693-60042

- a. See [“Clarifying the Terminology of a Connector Interface” on page 1-2.](#)
b. A 2.4 mm gage is capable of measuring 2.4 mm and 1.85 mm connectors.
c. See [“Printing Copies of On-Line Documentation” on page iv.](#)

Type-N (75 ohm) Modules and Accessories

Description ^a	Qty	Part Number
Adapters (added with Option 00A)		
Type-N (75 Ω) female to female adapter	1	85036-60014
Type-N (75 Ω) male to male adapter	1	85036-60013
Wrenches		
3/4 in, 135 N-cm (12 in-lb) torque wrench	1	8710-1766
1/2 in to 9/16 in open-ended wrench	1	8710-1770
Protective End Caps		
DB-25 multi-pin connector cap	as required	1252-4690
Type-N male connector cap	as required	1401-0248
Type-N female connector cap	as required	1401-0247
Gages		
Type-N (75 ohm) mm pin depth gages (male and female gages and masters)	1	85036B Option K01
Other		
Electronic calibration module reference manual ^b	1	N4693-90001
Connector care quick reference card (part of reference manual)	1	08510-90360
USB cable, 1.8 meters	1	8121-0506
Storage box for the ECal module and accessories	1	N4693-60042

a. See “Clarifying the Terminology of a Connector Interface” on page 1-2.

b. See “Printing Copies of On-Line Documentation” on page iv.

Type-F Modules and Accessories

Description ^a	Qty	Part Number
Adapters (added with Option 00A)		
Type-F female to female adapter	1	85039-60002
Type-F male to male adapter	1	85039-60006
Wrenches		
Type-F wrench (supplied with kit)	1	8710-1841
Protective End Caps		
DB-25 multi-pin connector cap	as required	1252-4690
Type-F male connector cap	as required	1401-0297
Type-F female connector cap	as required	1401-0296
Other		
Electronic calibration module reference manual ^b	1	N4693-90001
Connector care quick reference card (part of reference manual)	1	08510-90360
USB cable, 1.8 meters	1	8121-0506
Storage box for the ECal module and accessories	1	N4693-60042

- a. See [“Clarifying the Terminology of a Connector Interface”](#) on page 1-2.
b. See [“Printing Copies of On-Line Documentation”](#) on page iv.

Other ECal Accessories

Description	Qty	Part Number
85097B ECal VNA Interface Kit		
Interface Unit	1	85097-60002
Shielded DB25 to DB25 Cables	3	8120-8710
Adapter cable, DB25 to AMP Champ (36-pin) <i>Option 100</i>	1	8121-1047
Power Supply	1	0950-3331
Reference Guide ^a	1	85091-90010
Quick Reference Card	1	85091-90011
Adapter Cable (connects N469xA/B series modules to 85097B)		
DB25 to AMP Champ (36-pin)	1	8121-1047
Cleaning Supplies		
Compressed air (235 ml)	1	8500-6659
99.5% isopropyl alcohol (8 oz)	1	8500-0559
99.5% isopropyl alcohol ^b	--	--
Cleaning swabs	100	9301-1243
Lint-free cleaning cloth	150	9310-4242
ESD Supplies		
Grounding wrist strap	1	9300-1367
5 ft Wrist-strap to table-mat grounding cord	1	9300-0980
2 x 4 ft conductive table mat with 15 ft ground wire	1	9300-0797
USB Accessories		
USB 4-port hub	1	N4689A
Module Accessories		
Rubber foot	1	85060-40001
Storage box for the ECal module and accessories	1	N4693-60042

a. See “Printing Copies of On-Line Documentation” on page iv.

b. Agilent can no longer safely ship isopropyl alcohol, so customers should purchase it locally.

Numerics

- 85060B (discontinued)**
 - connector type, 1-10
 - frequency range, 1-10
- 85062B (discontinued)**
 - connector type, 1-10
 - frequency range, 1-10
- 85064B (discontinued)**
 - connector type, 1-10
 - frequency range, 1-10
- 85091C**
 - characteristic performance, 5-5
 - connector type, 1-4
 - frequency range, 1-4
 - replaceable parts, 6-2
- 85092C**
 - characteristic performance, 5-5
 - connector type, 1-4
 - frequency range, 1-4
 - replaceable parts, 6-3
- 85093C**
 - characteristic performance, 5-5
 - connector type, 1-4
 - frequency range, 1-4
 - replaceable parts, 6-4
- 85096C**
 - characteristic performance, 5-5
 - connector type, 1-4
 - frequency range, 1-4
 - replaceable parts, 6-9
- 85098C**
 - characteristic performance, 5-6
 - connector type, 1-4
 - frequency range, 1-4
 - replaceable parts, 6-5
- 85099C**
 - characteristic performance, 5-6
 - connector type, 1-4
 - frequency range, 1-4
 - replaceable parts, 6-10

A

- accuracy of ECal vs. mechanical cal**, 1-2
- adapter cable**
 - connection to module, 2-12
 - part number, 6-11
- adapter removal calibration**, 3-4
- Agilent Technologies**
 - contacting, 1-15
 - returning an ECal, 1-16
- alcohol, cleaning connectors**, 4-5

B

- barometric pressure**, 5-4

C

- calibration**
 - adapter removal, 3-4
 - adjustments, 3-2
 - advanced settings, 3-3
 - isolation, 3-3
 - non-insertable device, 3-4
 - perform a calibration, 3-6
 - setting up, 3-2
 - types available, 3-3
 - unknown thru, 3-4
 - user-characterization, 3-4
 - why validate accuracy, 3-7
- center conductor**
 - pin depth, 5-12
- characteristic performance**
 - 85091C, 5-5
 - 85092C, 5-5
 - 85093C, 5-5
 - 85096C, 5-5
 - 85098C, 5-6
 - 85099C, 5-6
 - N4431B, 5-7, 5-8
 - N4432A, 5-9
 - N4433A, 5-9
 - N4690B, 5-10
 - N4691B, 5-10
 - N4692A, 5-10
 - N4693A, 5-11
 - N4694A, 5-11
 - N4696B, 5-11
- characteristics**
 - connector, type-N, 5-13
 - mechanical, 5-12
- cleaning**
 - connectors, 4-5
- cleaning supplies**, 6-11
- collet**, 4-7
- compatible network analyzers**, 1-13
- compressed air or nitrogen**, 4-5
- confidence check**, 3-7
 - how to perform, 3-7
- connecting ECal module**, 2-10
- connection**
 - ENA analyzer, 2-10
 - to interface, 2-12
 - to USB port, 2-10
 - VNA analyzer, 2-12
- connections**, 4-15, 4-16, 4-18
 - 1.85 mm, 4-15

- 2.4 mm, 4-15
- 2.92 mm, 4-15
- 3.5 mm, 4-15
- 7 mm, 4-15
- type-F, 4-15
- type-N, 4-15
- connector**
 - cleaning, 4-5
 - fixed connectors, 4-7
 - precision 7 mm, 4-7
 - gaging, 4-8, 4-9, 4-14
 - pin depth
 - 1.85 mm, 5-17
 - 2.4 mm, 5-17
 - 2.92 mm, 5-16
 - 3.5 mm, 5-16
 - 7 mm, 5-15, 5-16
 - slotted, 4-4
 - visual inspection, 4-3
 - wear, 4-3
- connector gage**
 - accuracy, 4-8
 - handling, 4-14
 - master, 4-14
 - zeroing, 4-13
- connector wear**
 - causes, 4-3
- contacting Agilent**, 1-15
- container for storage**, 4-19

D

- damaged connectors**, 4-3
- declaration of conformity**, 1-20
- defective connectors**, 4-3
- definitions**
 - specifications, 5-2
- depth gage**
 - 7mm part number, 6-2
 - Type-N part number, 6-3
- device**
 - connecting, 4-15
 - disconnecting, 4-18
 - gaging, 4-14
 - handling and storage, 4-19
 - specifications
 - traceability, 1-17
 - visual inspection, 4-3
- dimensions, modules**, 5-20

E

- ECal**
 - adapter removal, 3-4
 - confidence check, 3-7

connecting and disconnecting, 2-10
ENA compatibility, 1-13
ENA connections, 2-10
factory characterization, 3-4
inspecting kit, 2-2
network analyzer compatibility, 1-13
network analyzer connections, 2-10
perform a calibration, 3-6
PNA compatibility, 1-13
PNA connections, 2-10
setting up, 2-10
storage box, 4-19
unknown thru, 3-4
user-characterization, 3-4
VNA compatibility, 1-13
VNA connections, 2-10

ECal module

overview, 1-2

ECal vs. mechanical cal, 1-2

electrostatic discharge (ESD), 4-2

ENA analyzer

connection to module, 2-10

environmental specifications, 5-3

ESD protection, 4-2

ESD supplies, 6-11

F

female connectors

inspection of, 4-4

G

gage

handling, 4-14

zeroing, 4-13

gage master, using, 4-8

gaging

connectors, 4-8, 4-9

procedure, 4-13

H

handling

of devices, 4-19

humidity, 5-4

I

inspecting ECal on arrival, 2-2

inspection

damage, 4-3

defects, 4-3

female connectors, 4-4

mating plane, 4-3

visual, 4-3

instrument markings, 1-19

interface kit, 6-11

isopropyl alcohol, cleaning, 4-5

K

kit contents

85091C, 2-3

85092C, 2-3

85093C, 2-3

85096C, 2-3

85098C, 2-3

85099C, 2-3

microwave four-port, 2-6

microwave two-port, 2-4

N4431B Opt. 010, 2-4

N4431B Opt. 020, 2-4

N4432A Opt. 020, 2-6

N4432A Opt. 030, 2-6

N4433A Opt. 010, 2-6

N4690B, 2-4

N4691B, 2-4

N4692A, 2-4

N4693A, 2-4

N4694A, 2-4

N4696B, 2-4

RF four-port, 2-4

RF two-port, 2-3

L

line drawings of modules, 5-20

M

maintenance, 4-2

making connections, 4-15

manual overview, 1-2

markings, instrument, 1-19

mating plane surfaces

inspection, 4-3

measurements, modules, 5-20

mechanical cal vs. ECal, 1-2

mechanical characteristics, 5-12, 5-18

center conductor protrusion,

5-12

microwave, 5-18

RF, 5-18

type-N, critical, 5-13

mechanical dimensions

8509x modules, 5-20

N4431B module, 5-21

N4432A & N4433A modules, 5-23

N469xA/B modules, 5-22

module

mechanical dimensions, 5-20

modules

microwave (discontinued), 1-10

microwave 2-port, 1-8

microwave 4-port, 1-11

performance

verification, 1-14

RF 2-port, 1-4

RF 4-port, 1-6

N

N4431B

characteristic performance, 5-7, 5-8

connector type, 1-6

frequency range, 1-6

mixed connector options, 1-6

replaceable parts, 6-3, 6-4

N4432A/3A

characteristic performance, 5-9

connector type, 1-11

frequency range, 1-11

mixed connector options, 1-11

N4690B

characteristic performance, 5-10

connector type, 1-8

frequency range, 1-8

replaceable parts, 6-3

N4691B

characteristic performance, 5-10

connector type, 1-8

frequency range, 1-8

replaceable parts, 6-4

N4692A

characteristic performance, 5-10

connector type, 1-8

frequency range, 1-8

replaceable parts, 6-6

N4693A

characteristic performance, 5-11

connector type, 1-8

frequency range, 1-8

replaceable parts, 6-7

N4694A

characteristic performance, 5-11

connector type, 1-8

frequency range, 1-8

replaceable parts, 6-8

N4696A/B
frequency range, 1-8
N4696B, 5-10
characteristic performance, 5-11
connector type, 1-8
replaceable parts, 6-2
National Institute of Standards and Technology (NIST), 1-17
nitrogen, cleaning connectors, 4-5
non-insertable calibration, 3-4

O

on arrival
inspecting, 2-2
recording serial numbers, 2-2
operating
connector care, 2-8
ESD precautions, 2-8
handling, 2-9
input level, 2-9
operating temperature, 2-9
precautions, 2-8
temperature, 5-3
overview
ECal module, 1-2

P

physical dimensions of modules, 5-20
pin depth characteristics
1.85 mm, 5-17
2.4 mm, 5-17
2.92 mm, 5-16
3.5 mm, 5-16
7 mm, 5-16
type-N, 5-15
pin depth information, 5-12
PNA analyzer
connection to module, 2-10
prerequisite knowledge, 2-8
procedure, gaging, 4-13
protrusion definition, 5-12

R

reading connector gage, 4-9
recertification
how often, 1-17
how to order, 1-17
verification, 1-14
where to send, 1-17
recession definition, 5-12

recording serial numbers, 2-2
relative humidity, 5-4
replaceable parts
1.85 mm, 6-8
2.4 mm, 6-7
2.92 mm, 6-6
3.5 mm, 6-4
7 mm, 6-2
7 mm depth gage, 6-2
7-16, 6-5
85091C, 6-2
85092C, 6-3
85093C, 6-4
85096C, 6-9
85097B, 6-11
85098C, 6-5
85099C, 6-10
N4431B, 6-3, 6-4
N4690B, 6-3
N4691B, 6-4
N4692A, 6-6
N4693A, 6-7
N4694A, 6-8
N4696B, 6-2
Type-F, 6-10
Type-N 50 ohm, 6-3
Type-N 75 ohm, 6-9
Type-N depth gage, 6-3
returning an ECal to Agilent, 1-16
rubber foot, 6-11

S

safety and regulatory information, 1-18
separating connections, 4-18
serial numbers, 2-2
service
recertification, 1-14
setting up calibration, 3-2
7 mm depth gage
part number, 6-2
specifications
download descriptions, 5-24
environmental, 5-3
terminology and definitions, 5-2
torque wrench, 4-16
traceability, 1-17
specifications and characteristics
accuracy-enhanced temperature range, 5-3
connector pin depth values, 5-2
error-corrected temperature range, 5-2
measurement calibration, 5-2

operating temperature range, 5-2
standards
National Institute of Standards and Technology (NIST), 1-17
static discharge, 4-2
storage
of devices, 4-19
storage box, 4-19
supplemental characteristics
mechanical, 5-18

T

temperature
operating, 5-3
terminology
specifications, 5-2
torque wrench
connector types, 4-18
part numbers, 4-18
selection, 4-18
settings, 4-18
torque wrench connections
microwave, 4-16
RF, 4-16
traceability
of device specifications, 1-17
type-N depth gage
part number, 6-3

U

uncertainty calculator
web address to download, 5-24
USB Hub, 6-11
user-characterization, 3-4

V

validate accuracy, 3-7
verification
confidence check, 3-7
measure known standards, 3-7
visual inspection, 4-3
VNA analyzer
connection to module, 2-12

W

web address
download uncertainty calculator, 5-24

Z

zeroing, connector gage, [4-13](#)